

Final Exam - Spring 2008-2009

Name : _____

CM Number : _____

Record all your answers to the multiple choice problems (1-15) by filling in the appropriate circle. All multiple choice answers will be graded from these markings, not the marking on the problem pages. Therefore, *carefully* transcribe your answers. **No guessing on the multiple choice problems - you must show all your work for full credit.**

Problem	Answers						Score
1	<input type="checkbox"/> a	<input type="checkbox"/> b	<input type="checkbox"/> c	<input type="checkbox"/> d	<input type="checkbox"/> e	<input type="checkbox"/> f	/2
2	<input type="checkbox"/> a	<input type="checkbox"/> b	<input type="checkbox"/> c	<input type="checkbox"/> d	<input type="checkbox"/> e	<input type="checkbox"/> f	/2
3	<input type="checkbox"/> a	<input type="checkbox"/> b	<input type="checkbox"/> c	<input type="checkbox"/> d	<input type="checkbox"/> e	<input type="checkbox"/> f	/2
4	<input type="checkbox"/> a	<input type="checkbox"/> b	<input type="checkbox"/> c	<input type="checkbox"/> d	<input type="checkbox"/> e	<input type="checkbox"/> f	/2
5	<input type="checkbox"/> a	<input type="checkbox"/> b	<input type="checkbox"/> c	<input type="checkbox"/> d	<input type="checkbox"/> e	<input type="checkbox"/> f	/2
6	<input type="checkbox"/> a	<input type="checkbox"/> b	<input type="checkbox"/> c	<input type="checkbox"/> d	<input type="checkbox"/> e	<input type="checkbox"/> f	/2
7	<input type="checkbox"/> a	<input type="checkbox"/> b	<input type="checkbox"/> c	<input type="checkbox"/> d	<input type="checkbox"/> e	<input type="checkbox"/> f	/2
8	<input type="checkbox"/> a	<input type="checkbox"/> b	<input type="checkbox"/> c	<input type="checkbox"/> d	<input type="checkbox"/> e	<input type="checkbox"/> f	/2
9	<input type="checkbox"/> a	<input type="checkbox"/> b	<input type="checkbox"/> c	<input type="checkbox"/> d	<input type="checkbox"/> e	<input type="checkbox"/> f	/2
10	<input type="checkbox"/> a	<input type="checkbox"/> b	<input type="checkbox"/> c	<input type="checkbox"/> d	<input type="checkbox"/> e	<input type="checkbox"/> f	/2
11	<input type="checkbox"/> a	<input type="checkbox"/> b	<input type="checkbox"/> c	<input type="checkbox"/> d	<input type="checkbox"/> e	<input type="checkbox"/> f	/2
12	<input type="checkbox"/> a	<input type="checkbox"/> b	<input type="checkbox"/> c	<input type="checkbox"/> d	<input type="checkbox"/> e	<input type="checkbox"/> f	/2
13	<input type="checkbox"/> a	<input type="checkbox"/> b	<input type="checkbox"/> c	<input type="checkbox"/> d	<input type="checkbox"/> e	<input type="checkbox"/> f	/2
14	<input type="checkbox"/> a	<input type="checkbox"/> b	<input type="checkbox"/> c	<input type="checkbox"/> d	<input type="checkbox"/> e	<input type="checkbox"/> f	/2
15	<input type="checkbox"/> a	<input type="checkbox"/> b	<input type="checkbox"/> c	<input type="checkbox"/> d	<input type="checkbox"/> e	<input type="checkbox"/> f	/2
16							/10
17							/20
18							/20
19							/20
Total							/100

Show all work for credit

EM121Statics and Mechanics of Materials I

For problems 1-15, circle the best answer and *then copy it to the coversheet*. You must show all work for full credit.

Problem 1

The projection of force vector $-3\hat{i} + 2\hat{j}$ N in the direction of the position vector \bar{r} shown at right is:

- a) 10 N
- b) 0.94 N
- c) -0.94 N
- d) -10 N
- e) None of the above

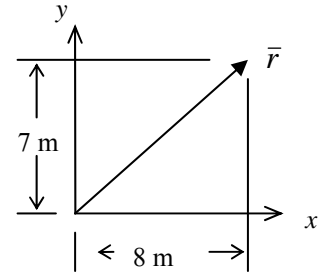
**Problem 2**

A rectangular plate is supported as shown at right. The tension in cable CD is expressed in vector form as $T_{CD} = -120\hat{i} + 96\hat{j} - 128\hat{k}$ N. The moment about point A created by this force is:

- a) $38.4\hat{i} - 48.0\hat{j} + 28.8\hat{k}$ N·m
- b) 65 N·m
- c) 68 N·m
- d) $-7.68\hat{i} + 28.8\hat{j} + 28.8\hat{k}$ N·m
- e) None of the above

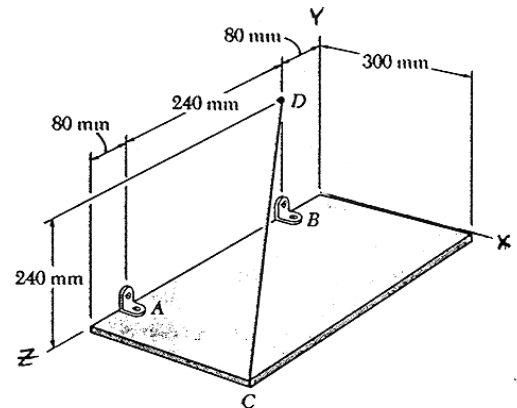

Problem 3

For the system shown at right, identify the correct free body diagram for the frictionless pulley

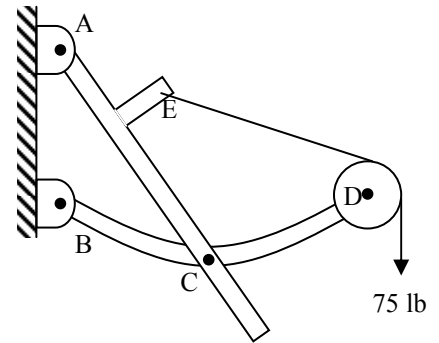

- a) b) c) d) e) none shown

Problem 4

We push on a cabinet of weight, W with horizontal force, P . From the analysis shown, we have found the critical height “ h ” that is the transition between slip and tip. (If the force is above h the cabinet will tip and below h the cabinet will slip). If we are able to lower the center of gravity of the cabinet, the critical height, h , will

$$\sum F_x = 0$$

$$P - \mu N = 0$$

$$\sum F_y = 0$$

$$W - N = 0$$

$$\sum M_{\text{corner}} = 0$$

$$(b/2)(W) - Ph = 0$$

FBD

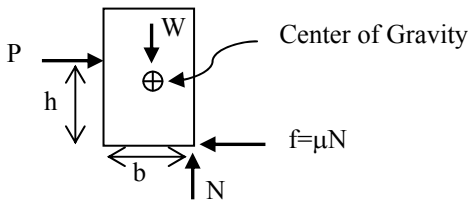

- a) increase b) decrease c) stay the same d) can't tell from given

Problem 5

Consider the glued joint shown below:

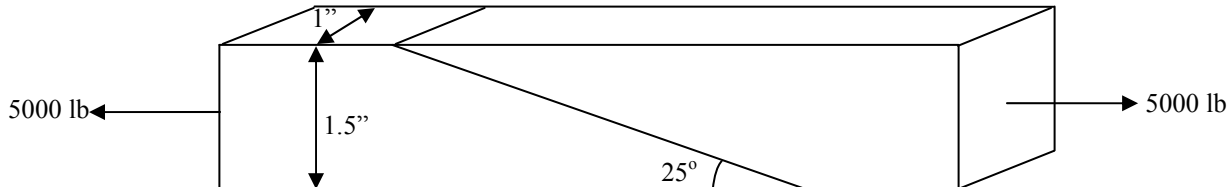

What is the normal stress in the glue?

- (a) 1410 psi
- (b) 2740 psi
- (c) 595 psi
- (d) 251 psi
- (e) 1160 psi
- (f) None of the above.

Problem 6

In a ship unloading operation, a 3500-lb automobile is supported by a cable. A rope is tied to the cable at A and pulled in order to center the automobile over the intended position. The angle between the cable and the vertical is 2° , while the angle between the rope and the horizontal is 30° . If the tension in the cable is 3574 pounds, what tension is needed in the rope for equilibrium?

- a) 125 lb
- b) 144 lb
- c) 249 lb
- d) 2490 lb
- e) None of the above

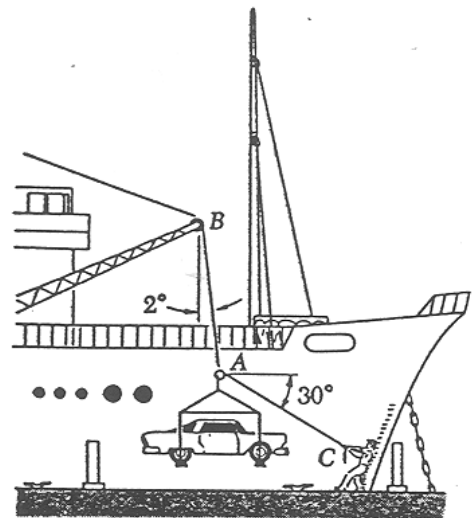

Problem 7

The external reaction at C of the simple cantilever truss shown at right is:

- a) 28 kips →
- b) 28 kips ←
- c) 36 kips →
- d) 36 kips ←
- e) None of the above

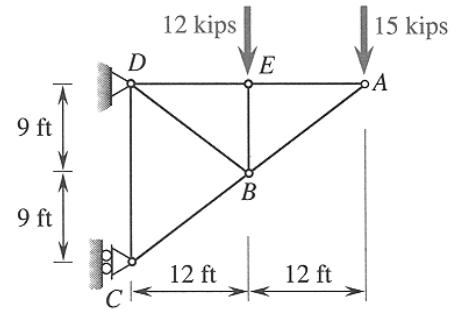

Problem 8

For the truss with external reactions shown at right, the force in member BC is

- a) Zero
- b) $wF/2h$ (compression)
- c) wF/h (tension)
- d) $wF/2h$ (tension)
- e) None of the above

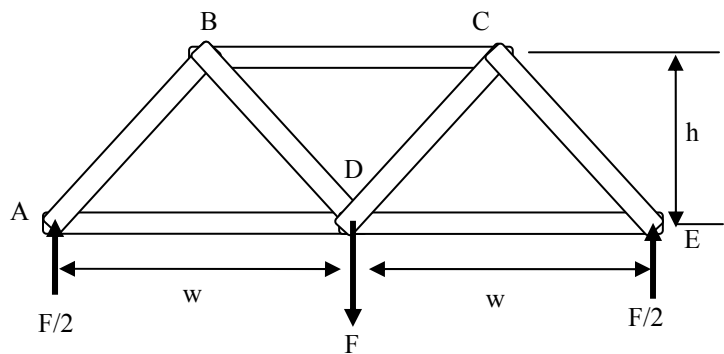

Problem 9

A uniform bar, ABCD, whose cross sectional area is 0.5 in^2 is loaded with the forces shown.

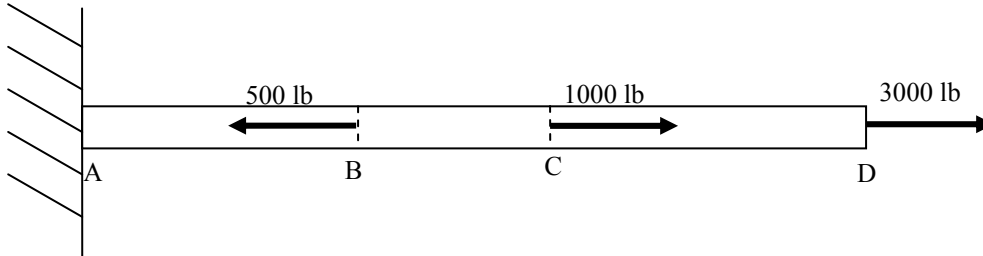

The tensile stress in section BC of the bar is

- a) 2000 psi
- b) 1000 psi
- c) 6000 psi
- d) 4000 psi
- e) 8000 psi
- f) None of the above

Problem 10

In a tug of war contest between two fraternities, each of the two teams is pulling with 600 pounds of force. Assume that the cross-sectional area of the rope is 0.1 in^2 and is made of a material with a failure strength of 15000 lb/in^2 . The factor of safety (FOS) is

- a. 25
- b. 5
- c. 2.5
- d. 1.25
- e. 0.8
- f. None of the above



Problem 11

What is the y coordinate of the centroid of the object shown at right?

- a) 1.85 in
- b) 1.67 in
- c) 1.33 in
- d) 1.15 in
- e) None of the above

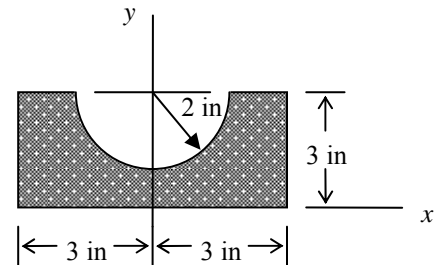
**Problem 12**

A bar ($A=0.4 \text{ in}^2$, $L = 40 \text{ in}$, $E = 10 \times 10^6 \text{ psi}$) fits into a gap between two rigid supports because its length is 0.01 in less than the gap. The temperature is increased in a way that would cause the bar to increase in length by 0.015 in due to thermal expansion if the wall was not present.

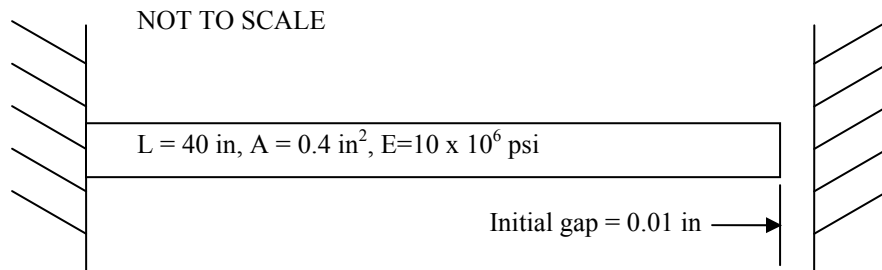

The stress in the bar after the full temperature increase is:

- a) 0 psi
- b) 1250 psi C
- c) 1250 psi T
- d) 2500 psi C
- e) 2500 psi T
- f) None of the above

Problem 13

Consider the rigid beam supported by two elastic bars as shown. It pivots about a pin support on its left end.

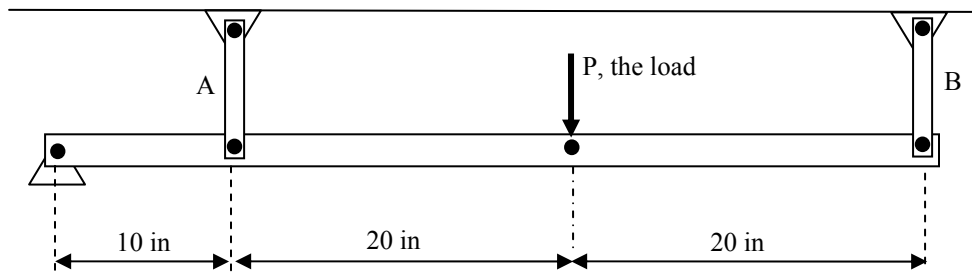

Which statement is true regarding the forces in IDENTICAL members A and B?

- a) $F_A = F_B$
- b) $F_A = (0.5) F_B$
- c) $F_A = (2.0) F_B$
- d) $F_A = (0.2) F_B$
- e) None of the above

Problem 14

A 100 lb block sits on a rough horizontal surface. A 20 lb force acts horizontally as shown. The frictional force between the block and the ground is

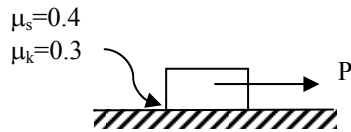

- a) 0lb b) 10lb c) 20lb d) 30lb e) 40lb f) none of these/can't tell from given

Problem 15

We have a block on a slope that is at incipient (impending) slip. The correct equation for the friction force is

- a) $f = \mu_s N$ b) $f = \mu_k N$ c) $f < \mu_s N$ d) $f > \mu_s N$ e) can't tell from given

Problem 16 (10 pts)

A tension joint has the basic layout shown in the 2 principal views below. (All dimensions on the diagram are in inches.) A single pin of diameter 0.5 inches ($A = 0.2 \text{ in}^2$) holds together the yoke and bar as shown. The material has an ultimate strength in tension of 80 ksi, and an ultimate strength in shear of 45 ksi. The load P has a value of 10000 lb.

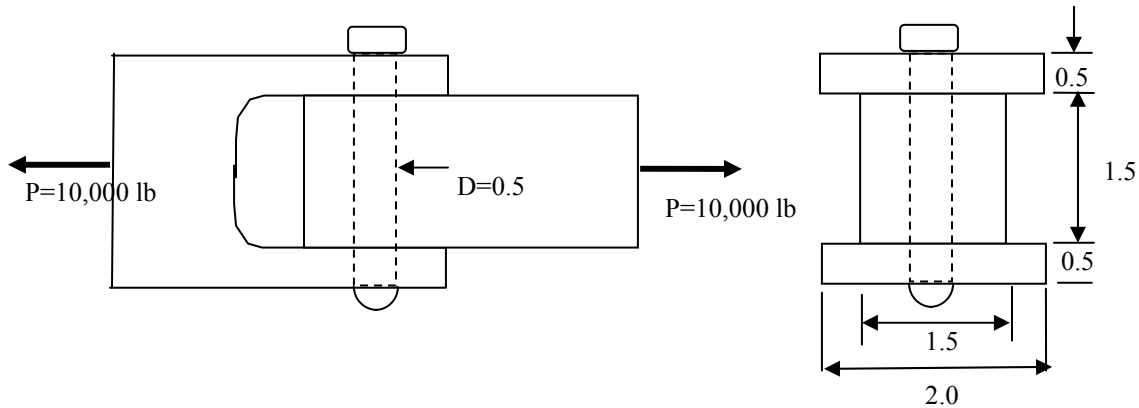

By examining the pin, the yoke, and the bar, find the overall factor of safety for the joint.

Problem 16 (cont.)

Problem 17 (20 pts)

For the system shown at right, determine the reactions at the fixed support O (assume it is welded there). *There is more space on the next page.*

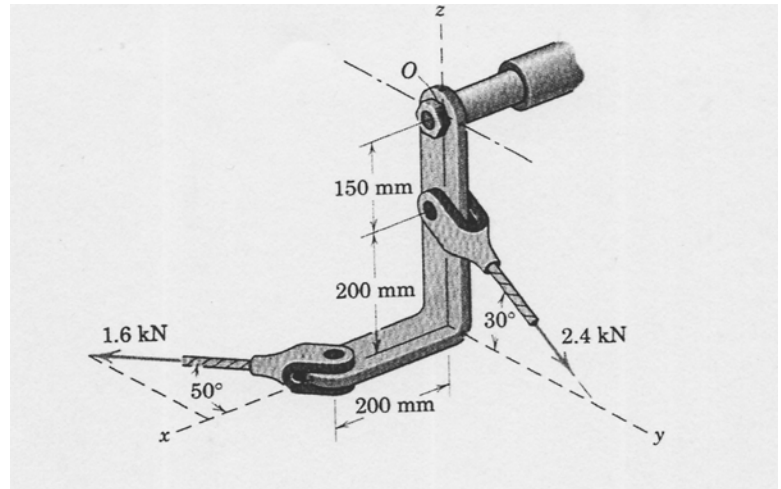

Problem 17 (cont.)

ROSE-HULMAN INSTITUTE OF TECHNOLOGY
Department of Mechanical Engineering

EM121Statics and Mechanics of Materials I

Problem 18 (20 pts)

A landing gear mechanism similar to the one used in the project is shown in the accompanying figure. You may assume that it is in static equilibrium in the configuration shown. You may neglect all of the weight except that of the strut and wheel (225 lb) which is located at point G. The force F, applied to member BCD, drives the retraction.

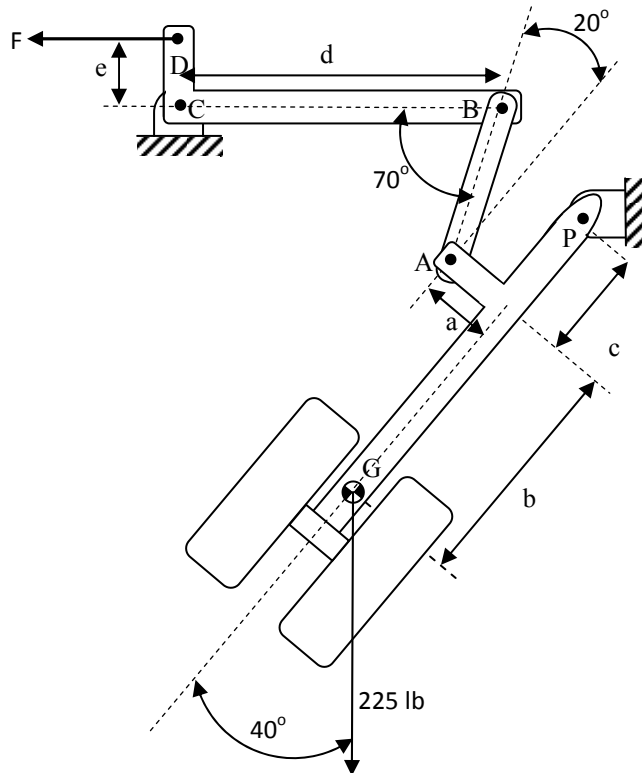

a	2.5"
b	36"
c	6"
d	16"
e	4"

Find:

- The force in link AB. (*Hint: Use a coordinate system aligned with the wheel strut.*)
- The magnitude of the pin force at the pin at P.
- The force F required for static equilibrium. (*Hint: Now use a coordinate system aligned with the BC axis.*)

There is more space on the next page.

ROSE-HULMAN INSTITUTE OF TECHNOLOGY
Department of Mechanical Engineering

EM121 Statics and Mechanics of Materials I

Problem 19 (20 pts)

Consider the A-frame shown. *Note: ABC is a single member, BCD is a single member, and BDF is a single member. This is not a truss.*

(a) Calculate the pin forces at B, C and D. (You can neglect the weight of the structural members.)

(b) The pins joining the A-frame are in single shear. The pins at B, C, and D have cross-sectional areas of 0.25 in^2 . They will fail when the shear stress reaches 20,000 psi. The other pins have much larger cross-sectional areas and will not fail first. Determine whether failure occurs, and whether the failure is at pin B, C, or D.

There is more space on the next page.

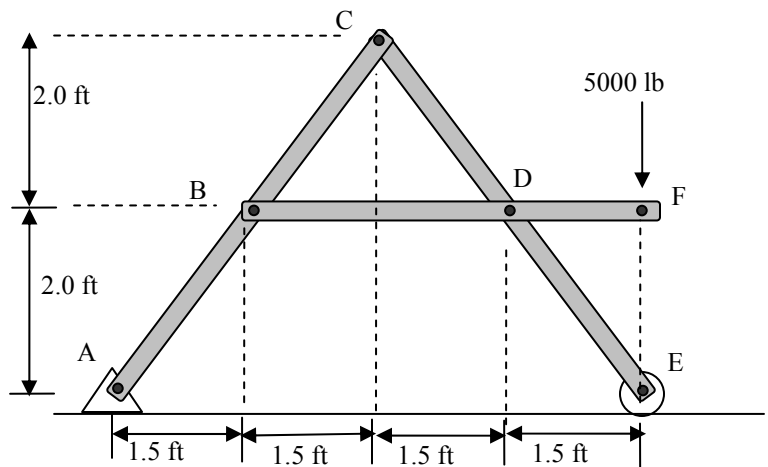

Problem 19 (cont.)