

# The EC909-12 Analog Microprocessor

*Thanks to this amazing breakthrough,  
the days of the digital microprocessor  
could be numbered.*

In the days before digital processors, calculations were often-times carried out using purely analog computers. Operations like addition, subtraction, and multiplication were performed using the appropriate circuits to act on DC voltage levels. After passing through the apparatus, the value of this output voltage could then be directly read as the answer. As an example, assume we wish to solve the equation  $x = \log(y+z)$  where  $y=7$  and  $z=2$ . In an analog computer,  $y$  and  $z$  would be adjusted to 2 and 7 volts respectively, added to produce 9 volts in a simple voltage-summing circuit, and then passed through a DC amplifier with a log transfer function. The output could then be read with a voltmeter as 0.954 volts, the same answer you would get with your digital calculator!

With the advent of digital computers, analog computers were effectively retired. Today's microprocessor is versatile, relatively inexpensive, and fairly fast, allowing us to have tremendous computing power in a small desktop or notebook package. There is, however, a company with a new product challenging current digital technology. The price and performance benefits of their new devices may possibly dethrone the digital microprocessor forever. All of this, while speeding up our desktop computers by over 3 orders of magnitude.

The company is Ecraf Technology Corp. (ETC). Based in Sarasota, FL and with offices world-wide, Ecraf (pronounced "EK-raff") has introduced a line of unbelievably fast analog processor chips that mirror the architecture of an Intel Pentium II MMX in the same "Slot 1"

configuration. These are designated as the 909-xx series of devices. When I first heard about their new products I called Ecraf on the phone and (to my astonishment) was connected directly to Dr. Wilhelm Ecraf, senior vice president and director of research and engineering (He is the youngest brother of Dr. Dieter Ecraf, founder and CEO of Ecraf Technology). By the end of our conversation he had sold me on their design philosophies, while I had convinced him to send me tons of their technical literature including most of the 127 patent submissions they have filed in the last 2 years. He also supplied me with a couple of the EC909-12 microprocessors for evaluation. I have since visited him in Sarasota and got to witness some of their research activities in person. I will try to summarize the key advantages of the 909-xx family below, and then give a personal test report.

**The Barrier Reflex Diode.** The key behind the EC-909 family of analog

microprocessors is a new electronic device called the "Barrier Reflex diode" (or BRD; most design engineers call them "birds"). The BRD works exactly the opposite of a conventional semiconductor diode and opens up a world of new applications. As you know, a conventional diode does not conduct in the forward direction until the "knee" or barrier voltage is reached, at which time it will conduct and maintain a generally fixed voltage drop. A Barrier Reflex diode, on the other hand, conducts perfectly, essentially like a superconductor but at ordinary room temperatures, until the knee voltage of 1.21576 volts is reached; It then becomes a near perfect insulator and ceases all forward conduction until the applied voltage falls below the barrier reflex voltage. The fortuitous knee voltage and the immeasurably small operating currents permit extended operation from tiny batteries.

Among the advantages of the device is that it performs like a perfect switch. The switching speed is

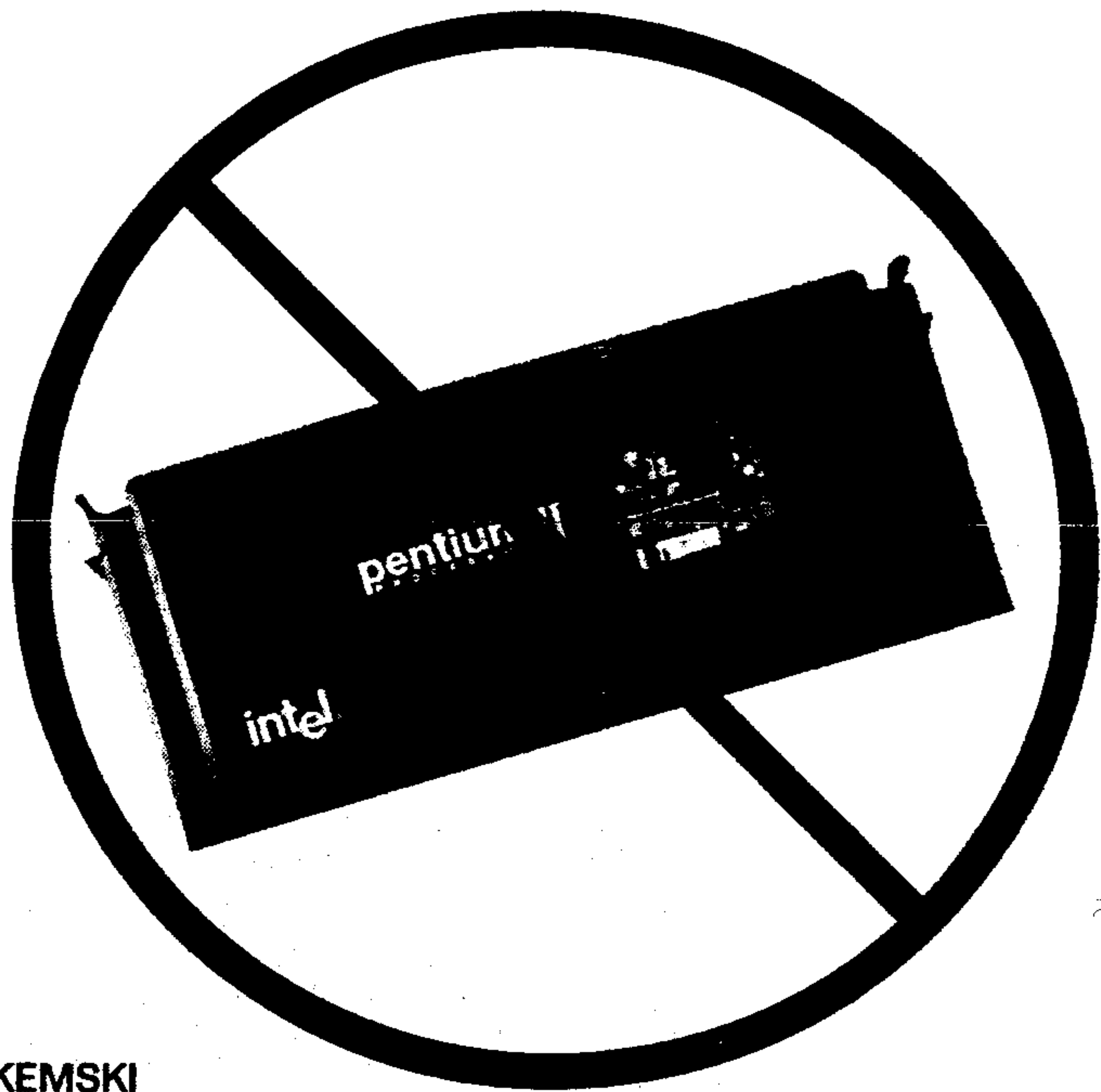

KEN KEMSKI



measured in fractions of a femtosecond ( $<1 \times 10^{-15}$  sec). When on, it is a perfect conductor (forward drop=0.00 V). When off, it is a near perfect insulator (current=0.00  $\mu$ A). The temperature coefficient of barrier reflex voltage is presently unmeasurable. It is simple and cheap to build. It integrates into monolithic circuits with ease. Its only disadvantage is that it produces large quantities of intense white light when operating.

Being a two terminal device, it is easy to design applications around it. A basic test setup is shown in Fig. 1. A simple lattice of 64 BRDs constitutes an ultra-high-performance bi-directional 64-bit A/D-D/A converter with less than 1 fs settling time and perfect accuracy. Twelve such arrays are integrated in Ecraf Technology's analog microprocessor designs as primary I/O.

*Editor's Note:* Designers should note that a serious applications problem still exists, in that BRD produces a prodigious amount of pure white light when it is in the conducting state. While packaged individually in its familiar hermetically sealed ceramic pellet (1BRD34), enough light still penetrates the "purportedly opaque" ceramic casing to "fill a room as if bathed in sunlight." Dr. Ecraf's brother Helmutt was reported to have been blinded in earlier experiments in 1995 with a BRD, before the housing was changed from clear glass to "opaque" ceramic. It has been calculated that the light produced from a simple 64-BRD lattice (0.01 square inches) conducting immeasurably small currents would be sufficient to light a small city! Until an opaque material is found that can contain this light, the BRD will probably find limited use, reserved for specialized applications such as the EC909 series of analog microprocessors.

Not that we know a little more about the Barrier Reflex diode, let's look at the EC-909 microprocessor in more depth.

**General.** The 909-xx family of analog microprocessors have the same pin assignments as an Intel Pentium II, but there the similarity ends. The data and address pins connect

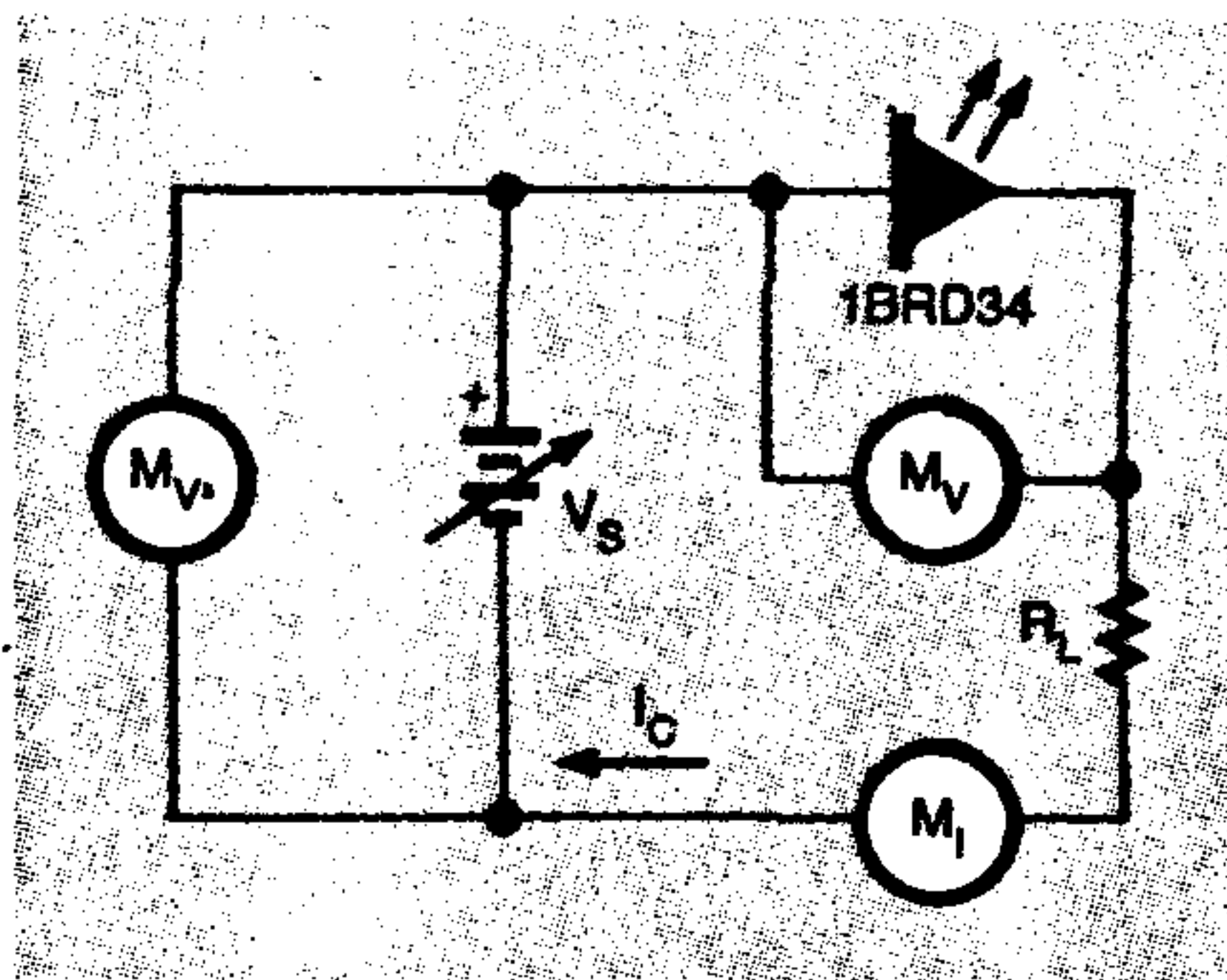

Fig. 1. Here's the basic setup for testing the 1BRD34 Barrier Reflex diode. Note, experimenters should wear appropriate eye protection when working with this device.

directly to ultra high-speed bi-directional 64-bit D/A converters, changing the digital words into analog voltages, using Barrier Reflex diodes, essentially at the speed of light. Those voltages are processed by a proprietary monolithic analog computer with a die size of only approximately 0.1-inch square. As the "voltage words" appear at the output, equally fast A/D converters feed them back to the motherboard where they can be handled conventionally. It is the monolithic analog computer that is the heart of the new technology, as it is the fastest processor ever produced by man. It leapfrogs current technology by at least a thousand-fold and will allow for the development of products never even dreamed of until now. "What's the big deal with analog?" you might ask. Read on.

**Speed.** A digital processor works from a "clock," or timing signal. With a clock of say, 300MHz, the time between clock cycles is just over 3 nanoseconds ( $3.33 \times 10^{-9}$  sec). That is, the microprocessor "does something" every clock cycle, or every 3+ nanoseconds. Most operations (such as adding 2 memory locations together and placing the result in a third location) consume several clock cycles. If the operation requires 8 clock cycles for example, it would take over 24 ns for that single operation to occur! Modern processors use parallel pipelines, split-phase clocks, and the like to try to do as much as possible in those time intervals, but the basic limitation remains. In Ecraf's analog processors, the voltages tra-

verse the small die essentially at the speed of light, providing fantastic virtual clock frequencies. Since the chip is about 0.1-inch square, and the speed of light is approximately 186,000 miles/sec., it takes only 4 picoseconds for the analog signal to ripple through and complete a command! This is about 3000-times faster than a 300-MHz digital processor, corresponding to a clock speed of over 900,000 MHz! Getting interested?

**Accuracy.** People think of digital computers as "accurate." In fact, accuracy is directly related to word length. Each numerical operation in a digital computer is rounded to the nearest least-significant bit, and thus serves as only an approximation of the right answer. In Ecraf's analog computer design, the operations are linear, and provide essentially infinite accuracy internally (the equivalent accuracy of a 4096-bit word, limited only by the noise floor). In fact, the only real accuracy limitation occurs when the analog answer is necessarily converted back to a 64-bit digital word. That is done only for compatibility with the rest of the computer external to the processor.

**Cost.** The modern digital CPU consists of millions of transistors on a fairly large die, and is necessarily expensive to design and manufacture. The Ecraf EC909-12 on the other hand has only about 400,000 elements, many of them simple-to-fabricate Barrier Reflex diodes, and is, overall, very easily manufactured. This is exemplified in its S.R.P. (Suggested Retail Price) of only \$12 US, and that will buy you the deluxe EC909-12 P9 (Virtual 900-GHz version). Their yield from fabrication wafers to packaged die is over 98% for these analog wonders!

**Memory.** Here is an unexpected bonus: We all know that among the various memory types (EDO, Fast Page Mode, SDRAM, etc.) the cheapest memory is analog RAM, or aRAM. We also know that at .004-ns (4-picosecond) latency, it is several thousands of times faster than the SDRAM we presently use in our purely digital computers. The problem



has been that modern CPUs do not (indeed cannot) utilize aRAM. Guess what? aRAM is a perfect match for the 909-xx series of CPUs! Not only is it as fast as the new generation of analog CPUs, but the cost per megabyte is less than one one-hundredth of major brand EDO or SDRAM memory modules (on a cost-per-megabyte basis). The EC909-xx series accepts up to 1024 gigabytes of installed aRAM, although that is more than many of our applications now require.

**Video.** A side benefit of purely analog processing is that the CPU can off-load the video processor to speed up video performance. VGA is an analog system, replacing the earlier EGA and TTL video modes that were digitally based. The industry went to analog video interfaces so the number of colors and corresponding perceived resolution would not be compromised and so that the speed could be increased as video technology advanced (Sound familiar?). By routing the video tasks through the EC909-12 via a simple driver patch, the video processing speed can be increased by several thousand-fold as well. This makes 300 frames/sec for 1600 x 1200 x 16.7 M game presentations a snap, something the AGP video bus can't even dream of.

**Mass Storage.** The magnetic storage we use in present hard-disk technology is also an essentially linear process. A "bit" recorded on the hard drive can assume virtually any value of magnetism, much like the musical waveforms we store on cassette tapes. A modern hard disk stores and retrieves the data digitally, as strictly 1s and 0s, saying in effect "if it's magnetized it's a 1, if not it's a 0." The EC909 series of analog processors improves on that technology markedly. It stores any of 4096 levels of magnetism in each bit location of the hard drive's platter, effectively multiplying its capacity by over 4000 times. A 4-gigabyte off-the-shelf drive becomes a 16,000 gigabyte drive with enhanced reliability in an analog computer system.

**Reliability.** A tremendous enhancement in operational reliability

is made available from new gate designs possible with pure analog computing. Instead of simply "OR" or "AND" or similar types of gates, analog logic has been synthesized as "MAY BE" and "SHOULD BE" gates. For example, your word processor is loading from the hard drive, and a bad byte comes along. Ordinarily, it will crash the program, yielding the dreaded message, "This Application Has Performed An Illegal Operation. . ." Since a computer is smart, it should say "This byte is obviously wrong and will crash the program. I SHOULD modify just one bit in this byte, and the program will load normally." The smooth nature of the waveforms of analog gates will do just that, discarding the obvious error, and permitting the system to continue loading the program. Another example is when you are keying in a password to a program. You type those letters, numbers, and punctuation only to make one small mistake. The analog logic says "MAY BE he meant to type his password correctly" and then supplies the proper keystrokes to the program. This is a savings in time and money, a computing improvement long overdue in this author's opinion.

#### Bibliography

"Analog Microcomputers" Dr. Wilhelm Ecrat, 1994

"A Close Look at the Light Emanating From Barrier Reflex Diodes" Dr. Helmut Ecrat, 1995

"Dynamic Range No Longer A Problem in Analog Computing" Dr. Dieter Ecrat, 1998

**Energy Efficiency.** The current consumption of the EC909-12 is 800  $\mu$ A at 1.5V. It will run for hundreds of hours from a single AA cell. We know that aRAM has always been a power miser, consuming only 1  $\mu$ A/megabyte active, 0.01  $\mu$ A/megabyte standby. This will allow notebook computers to be constructed to run for weeks continuously on a single AA alkaline cell. The Active Matrix LCD screen is still an obstacle when it comes to power, but it is, after all, digital. Dr. Ecrat has filed 12 new patent submissions detailing an analog LCD screen, but is rather close-lipped about that secret project. When I queried him

as to the excessive power required for both back-lighting and powering the active devices, he only said "Do you remember how you winced at the bright light emanating from a heavily shielded, forward-conducting Barrier Reflex diode?"

Well, there is more, but the aforementioned should give you some idea as to what promise this new technology holds. I have been using an EC909-12 P9 Analog Microprocessor for about a month now, and I will proceed to describe my experiences with it.

**Test Report.** My existing computer was built around an Asus P2B-LS motherboard powered by an Intel P2-400 processor with 256M. of SDRAM. I removed the P2-400 and SDRAM, and replaced it with the EC909-12 P9 and 4 gigabytes of aRAM that I obtained from Diamondback Electronics Co. The BIOS did not identify the processor correctly, so I manually set it up as a Pentium II with a processor speed of 900,000 MHz. Booting the computer took only a second or two. Wow! Was it fast! I tried to run various benchmarks on it, but they all reported "Overflow" errors. Typically, I'd double click on the program, and instantly a dialog box informing me of register or stack overflow would be reported. I called the publishers of "Super PC Speed Check" (on which my P2-400 measured 892), and they informed me "Our software is limited to calculating and displaying benchmarks up to 4,194,304," and "Who was I kidding, claiming that I overflowed that range? That would be over 4000 times faster than a P2-400!" I thanked them and went about further testing.

All of my software (with the exception of the benchmarks) ran flawlessly. Games were breathtaking, and the Ecrat video patch worked like a dream. Because of the analog processing, pixellization was eliminated, and the screens looked just like the photographs on the software packages. I did some checks on arithmetic computations performed with the original digital processor and then the EC909. The EC909 matched the first 24,000+ digits of

(continued on page 50)

---

# ANALOG MICROPROCESSOR

*(continued from page 46)*

---

the value of pi (as obtained from the "Handbook of Standard Mathematics"), while the original processor fumbled after only 207 digits. This was some processor!

With so much new hard disk space, I copied all of my CDs (over 4000 programs) directly to the hard drive. That speeded operations up immensely, although my desktop is a bit cluttered now. Perhaps the nicest result is that I have not had a single fatal error reported since the CPU swap. Thank you Dr. Ecraf for the "SHOULD BE" gate! Actually, the only complaint about the EC909-12 that I have is in regards to the intense light that emanates from the CPU module seams, I need to keep the case cover always closed as the light is annoying, especially when trying to play games in subdued light. If you opt for this microprocessor upgrade, be sure to look away from the module the first time it is turned on in case the ceramic cover on your CPU leaks light as mine did.

In any event, the EC909-12 Analog Microprocessor should be available to the general public by the time you read this. The scheduled release date is April 1.       $\Omega$