

Sampling

by Bruce A. Black

Objectives

To investigate sampling in the time and frequency domain.

Equipment

Tektronix 7L5 Spectrum Analyzer	1 TL072 dual op amp
Agilent 54634A Oscilloscope	1 2N3904 NPN transistor
±5 V Power Supply	1 2N3906 PNP transistor
Agilent 33250A Function Generator	2 diodes
Agilent 33120A Function Generator	6 1 kΩ resistors
Orange Butterworth Filter	BNC T-connector
1 4016 quad CMOS switch	

Pre-Lab

1. Calculate the Fourier transform $G(\omega)$ of $g(t) = p(t) \cos 2\pi 1000t$, where $p(t)$ is a 10% duty cycle pulse train switching between -5 V and 5 V at a fundamental frequency of 20 kHz. Plot the magnitude spectrum $|G(\omega)|$. On your plot identify the frequency of the first null in the envelope of the spectrum. Now calculate values of the spectral components in dBV as they will be measured using the spectrum analyzer.
2. Wire up the sampling circuit shown in Fig. 1. You are asked to wire up the circuit ahead of time so that lab time can be used for debugging and for the lab measurements. This sampler uses two op-amps as buffers for a CMOS switch, which takes the samples. The push-pull output circuit provides enough current to drive the 50 Ω orange butterworth filters. Note that the feedback loop goes around the push-pull circuit, making that circuit effectively a part of the op-amp.

Procedure

1. Using the oscilloscope, set up the AG33250A function generator to produce a 10% duty cycle pulse train at a fundamental frequency of 20 kHz. Set the “high level” and “low level” to produce pulses with a five-volt peak, measured open circuit, above a baseline of -5 volts (that is, ten volts peak-to-peak). During the experiment you may vary the fundamental frequency of the pulse train, but do not alter the high or low pulse levels. Connect the AG33250A output between the control input on the CMOS switch and ground.
2. Using the oscilloscope, set up the AG33120 function generator to produce a 1 kHz sine wave having zero offset and any amplitude up to a maximum of three volts peak, measured open-

circuit. Connect the sinusoid to the input of the sampling circuit. You may possibly have to reduce the amplitude of the 1 kHz sine wave to eliminate clipping in the output waveform.

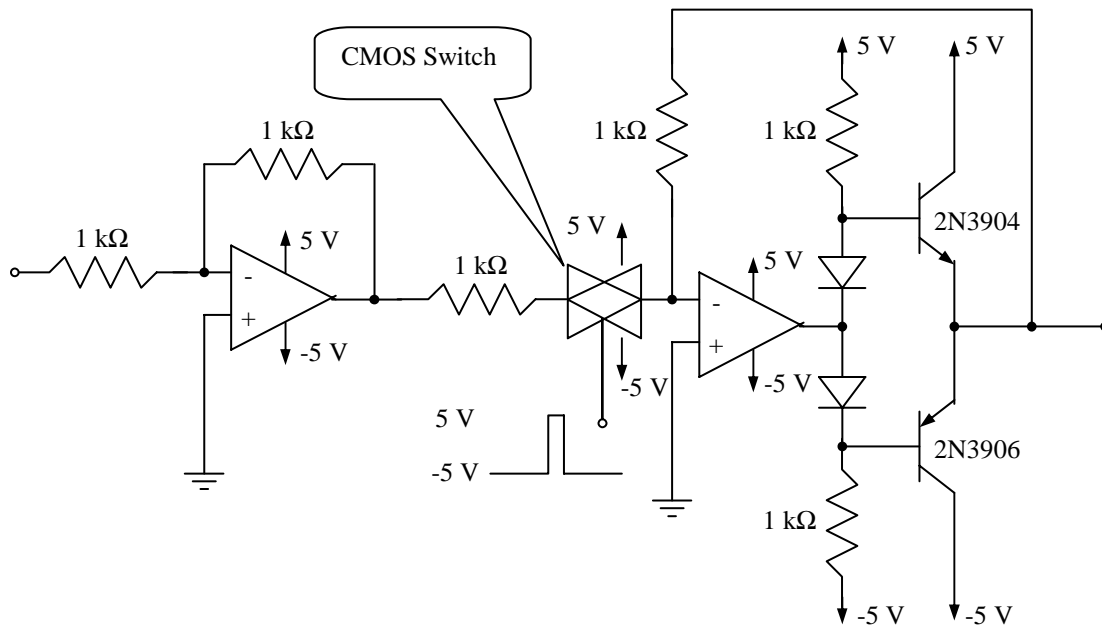

Figure 1: Sampling Circuit

3. Connect the output of the sampling circuit to the spectrum analyzer and to the oscilloscope. Make sure the TerminZ switch on the spectrum analyzer is set to $1\text{ M}\Omega$. Be sure to observe the cautions regarding maximum voltage and offset when using the spectrum analyzer.

Observe and sketch the sampled sinusoid as seen on the oscilloscope. (The oscilloscope will be *very* hard to synchronize. Try using external synch. Make two observations, one with synch taken from the pulse train, and one with synch taken from the sinusoid.)

4. Measure and record the spectrum as shown on the spectrum analyzer. In particular, determine the following: The frequency components of the baseband spectrum, the frequencies at which the baseband spectrum is duplicated, and the frequency at which the first null in the envelope of the spectrum occurs.
5. Vary the frequency of the sinusoid. What happens to the spectrum? Vary the frequency of the pulse train. What happens to the spectrum?
6. Connect the output of the sampling circuit to the input of the orange butterworth filter. Be sure that the filter is properly terminated in $50\ \Omega$. Observe the filter output on the oscilloscope and on the spectrum analyzer. What happens as the frequency of the input sinusoid is increased?

Continue increasing the frequency of the input sinusoid. Describe what you observe as the frequency approaches 20 kHz. (The output will be rather sensitive to input frequency, so use

small frequency steps.) Can you correlate the oscilloscope and spectrum analyzer measurements? Explain what is happening.

Report

Your lab notebook should contain the observations requested in step 3 through 6, including drawings of the oscilloscope and spectrum analyzer waveforms where appropriate. Compare the spectrum you observe in step 4 with the theoretical spectrum you obtained in the pre-lab calculation.