

BASICS OF SYSTEM NOISE THEORY

Presented by David Voltmer

20 June 1995

1. Noise is a random process based upon random motion of charges in materials.

A. In all **lossy** materials, electrons undergo random motion due to the thermal vibrations of the atoms of the material lattice which result in random currents.

B. All **active** devices (diodes, transistors, FETs, tubes) produce similar random currents and corresponding random noise.

C. The characteristics of random thermal (or so-called Johnson) noise are

- i. The direction (or the sign) of the currents is random.
- ii. The magnitude of the currents is gaussian.
- iii. The time of occurrence of the currents is random.
- iv. The spectrum of the noise is uniform for all radio frequencies; this is often called **white** noise in comparison to white light which has all frequencies of equal amplitude.
- v. The noise contribution from each device is usually considered to be **uncorrelated** with the contributions of all other devices. This allows noise powers of each device to be added to obtain the total circuit noise power.

D. In contrast to deterministic signals, random noise signals are described by a probability of a voltage rather than as a function of time, but their average power is predictable and observable.

E. For small signals (noise is seldom a problem for large signals) linearity is assumed. Under these conditions the total signal observed in a circuit is the desired message signal plus noise. For this situation the noise is called **Additive White Gaussian Noise** or **AWGN**.

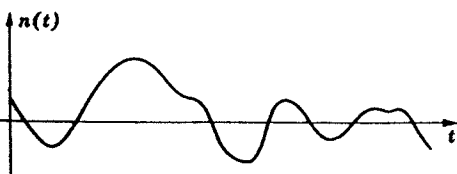
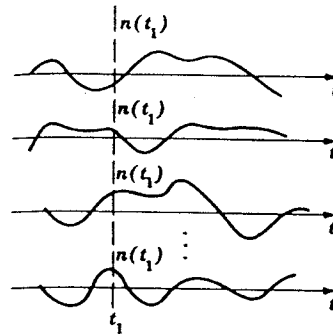
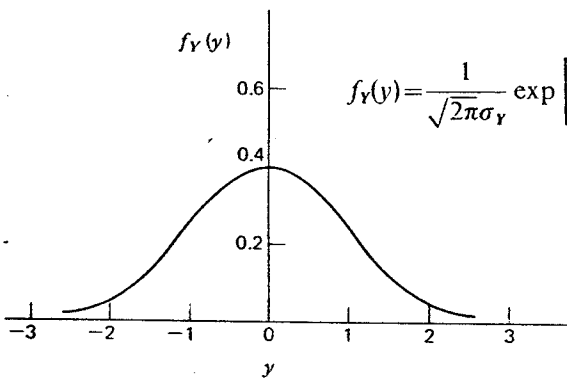
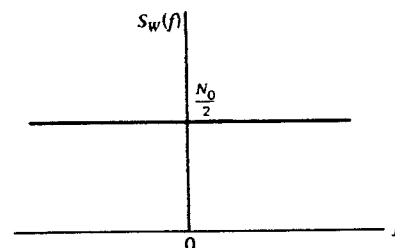

FIGURE 6-14
Random process.



2. Resistors - Thermal noise in resistors is defined in terms of available noise power.

A. **Available power** is the power delivered by a source to a match load; a **matched load** is the complex conjugate of the source's Thevenin impedance. Available noise power is defined as

$$P_{AVAIL} = |V_{THEV}|^2 / 4R_{THEV}$$

where V_{THEV} is the RMS time-averaged Thevenin equivalent (open circuit) voltage of the source and R_{THEV} is the Thevenin equivalent resistance of the source.

B. The open circuit RMS noise voltage squared observed across a resistor is given by

$$\langle v_N^2 \rangle = 4kTB$$

where

$\langle \rangle$ denotes the time average of the enclosed quantity,

$k = 1.38 \times 10^{-23}$ J/K, Boltzmann's constant,

T is the physical (or actual) temperature of the resistor (expressed in degrees Kelvin),

B is the noise bandwidth of the observing system in Hertz, and

R is the value of the resistor in Ohms.

C. The standard model for a noisy resistor is to place the voltage source $\sqrt{\langle v_N^2 \rangle} = 2\sqrt{kTB}$ in series with a noiseless resistor R. Superposition applies (since the noise sources are uncorrelated) in total noise calculations as well as signal calculations.

D. Using the results of part B in part A, the available noise power from a resistor is calculated as

$$P_N = kTB \text{ W.}$$

There is no dependence upon the size of the noise generating resistor.

E. The **noise bandwidth** of a system, B, is usually indistinguishable from 3 dB bandwidth of the system. The definition used here is most often used in telecommunications, the so called double-sided bandwidth which includes both positive and negative frequencies. Many system specifications are expressed in single-sided bandwidth using positive frequencies only. To convert P_N to single-sided bandwidth, the result in part C must be doubled.

F. The **noise power spectral density**, S_N , is defined as

$$S_N = P_N/B = kT \text{ W/Hz.}$$

The spectrum is flat, but depends upon the physical temperature of the resistor.

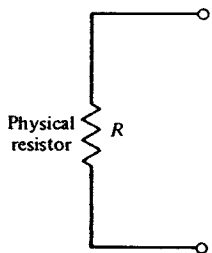

(a) A Lossy Circuit Element Characterized by Its Resistance

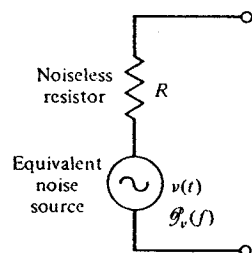

(b) Thevenin Equivalent Circuit Model of the Lossy Circuit Element

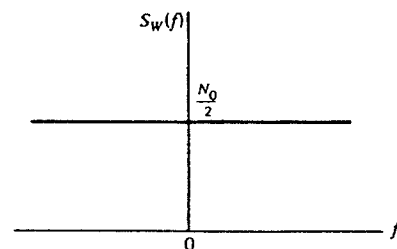

3. Diode Junctions - PN diode junctions generate a form of noise, shot noise. The available noise power from a forward biased diode is expressed as

$$P_N = kTB/2$$

where the diode must be matched to its dynamic resistance measured at DC Q-point. T is the actual junction temperature. This results in a noise power spectral density of

$$S_N = kT/2,$$

sometimes called the half spectral density.

4. FETs, BJT's, and tubes also generate noise; usually they function as two ports and have two independent noise sources. The BJT's actually contain two junctions with noise contributions as described for pn diodes.

5. Antennas - Very little noise is actually generated within an antenna, rather atmospheric noise is received by the antenna and passed along to a receiver. The available noise power from an antenna is expressed as

$$P_{ANT} = kT_{ANT}B$$

where T_{ANT} is the temperature at which the antenna terminal impedance would be held to correctly predict the noise power delivered by the antenna to a matched load.

A. Antenna noise temperature is dependent upon the antenna structure and upon the direction in which it points.

B. When the main beam (or significant sidelobes) of an antenna points at something relatively warm (the sun or the earth) it has a much higher noise temperature.

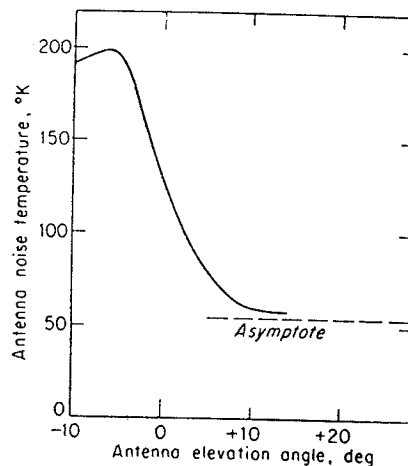
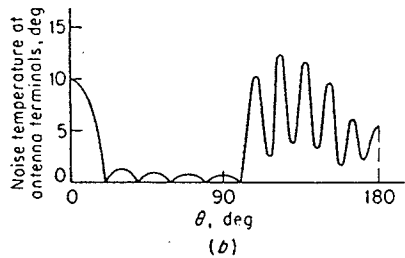
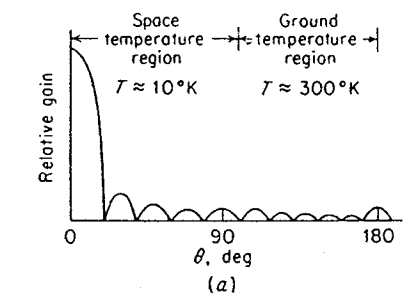
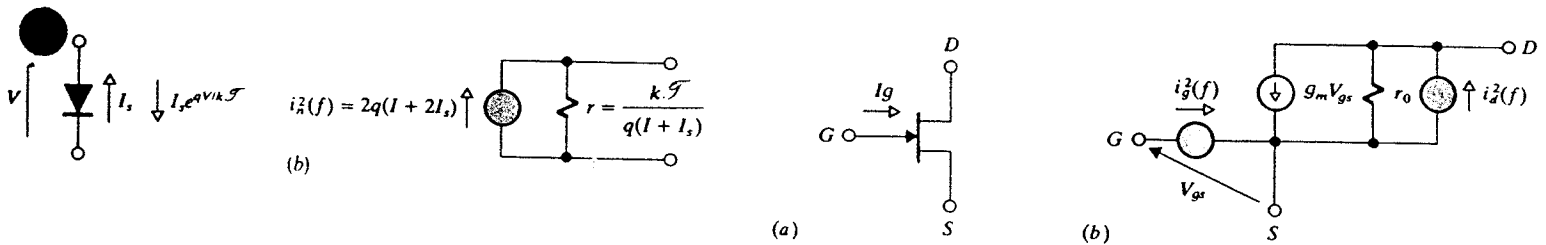

FIG. 8.9. (a) An antenna radiation pattern with the region in the vicinity of the main beam observing the space temperature and the region from about $\theta = 90^\circ$ to $\theta = 180^\circ$ observing the ground temperature; (b) profile of the noise temperature contributions weighted by the antenna pattern.

FIG. 8.10. Computed antenna noise temperature as a function of elevation angle for a 10-ft-diameter parabolic-reflector antenna operating at a frequency of 1,000 Mc. See text for assumptions. (After Greene,⁴³ courtesy Airborne Instruments Laboratory.)

6. **Noise Figure** - The noise performance of a two-port network is described by its noise figure, F , as

$$F = (S/N)_{IN} / (S/N)_{OUT}$$

the quotient of the input signal to noise power ratio to the output signal to noise power ratio. This assumes that the network input impedance provides the proper impedance match for the source to which it is connected and that it is terminated by a matched load so that available power is delivered to the two-port and it in turn delivers available power to its load.

A. For a two-port with a (matched) power gain of G , the input signal and input noise are both amplified by G ; their ratio remains unchanged.

B. Internally generated noise power is added (the noise sources are assumed uncorrelated so noise powers can be added) to the amplified source noise power so that the output noise power is given by

$$N_{OUT} = GN_{SOURCE} + N_{INT}$$

The second term decreases the output signal to noise power ratio and increases F . If there were no internally noise generated within the two-port, then $F = 1$.

C. These discussions are related to the **spot noise figure** or **single-frequency noise figure**.

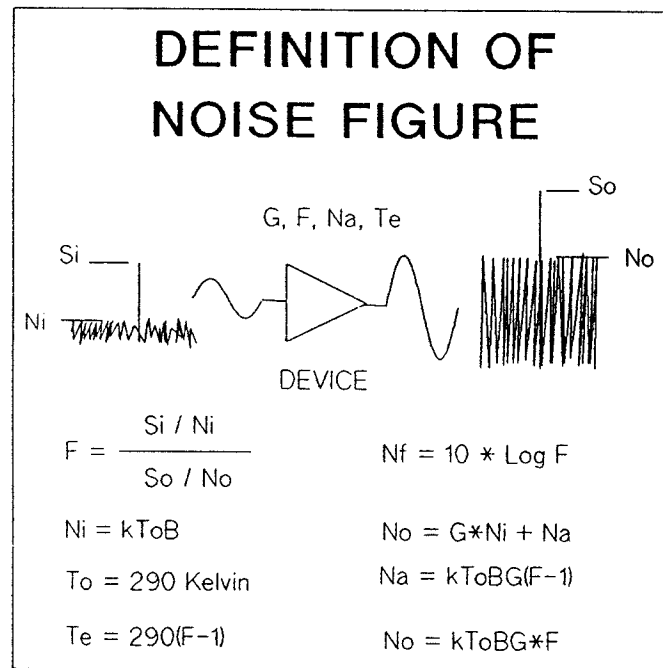

7. Model for Noise Calculations - The internal noise power, N_{INT} , is modeled by considering it to be generated by an effective noise source with an **effective input noise temperature** of T_{EFF} located at the input of an identical, but noiseless, two-port. This means that

$$N_{INT} = kT_{EFF}B.$$

A. T_{EFF} is not the actual temperature of the network; it is an artificial temperature which will lead to correct calculations for the noise power generated internally in the actual two-port.

B. The noiseless two-port part of the model has the same components, the same gain, the same bandwidth as the actual network except that it has not internal noise; that has been taken into account by T_{EFF} located at the network input.

C. Reference to the input of the two-port is an arbitrary choice; the output could have been chosen just as well. However, the input is the point at which the signal source or the antenna is connected and is a convenient reference point as the signal to noise power ratio is often known at this point.

D. This leads to the expression for output noise power as

$$N_{OUT} = GkT_{SOURCE}B + GkT_{EFF} = Gk(T_{SOURCE} + T_{EFF})$$

which leads to noise figure expressed as

$$F = [S_{IN}/kT_{SOURCE}B]/[GS_{IN}/(Gk(T_{SOURCE} + T_{EFF}))]$$

$$= (T_{SOURCE} + T_{EFF})/T_{SOURCE} = 1 + T_{EFF}/T_{SOURCE}.$$

E. If there is no internal noise then $T_{EFF} = 0$ and $F = 1$.

F. But to make noise figure independent of source temperature, the source temperature (except in the case of antennas) is defined as the **standard noise temperature**, $T_0 = 290^\circ\text{K}$ so that the **standard noise figure** is defined as

$$F = 1 + T_{EFF}/T_0.$$

G. An alternative for low-noise systems is to describe the two-port noise characteristic in terms of **effective input noise temperature** as

$$T_{EFF} = (F - 1)T_0.$$

That portion of the output noise power generated within the two-port can be written as

$$N_{OUT} = kGBT_{EFF}.$$

The internal noise power is proportional to effective input noise temperature.

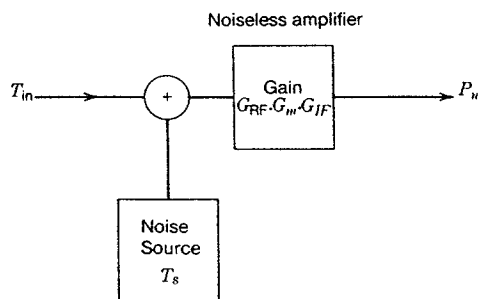

Figure 4.5b Equivalent circuit of receiver. All noisy units have been replaced by one noiseless amplifier, with a single noise source T_s as its input.

8. Noise characteristics for cascaded two-ports - Most systems consist of several two-ports connected in cascade. Consider a system consisting of two, noisy two-ports in cascade; the first is described by an effective input noise temperature of T_1 and a matched power gain of G_1 ; the second by T_2 and G_2 . The cascaded networks have a combined gain of $G_{TOT} = G_1G_2$. The output noise power generated within the two ports is given by

$$N_{OUT} = kB(G_1G_2T_1 + G_2T_2) = kG_1G_2B(T_1 + T_2/G_1) = kG_{TOT}B(T_1 + T_2/G_1).$$

Comparing this with the expression for N_{OUT} of part 6G gives the effective input noise temperature as

$$T_{EFF} = T_1 + T_2/G_1$$

and the system noise figure as

$$F = 1 + T_{EFF}/T_O = 1 + (T_1 + T_2/G_1)/T_O = F_1 + (F_2 - 1)/G_1.$$

A. The output noise power generated within the system depends primarily upon the first stage noise because it is amplified by both stages. The noise of the second stage is amplified only by the last stage and so contributes less than that of the first stage.

B. A low-noise, high-gain first stage results in the best noise performance.

C. The expressions for T_{EFF} and F can be generalized to a N -stages in cascade as

$$F = F_1 + (F_2 - 1)/G_1 + (F_3 - 1)/G_1G_2 + \dots + (F_N - 1)/G_1G_2 \dots G_{N-1}.$$

and

$$T_{EFF} = T_1 + T_2/G_1 + T_3/G_1G_2 + \dots + T_N/G_1G_2 \dots G_{N-1}.$$

D. The best combination of multi-stage systems is determined by direct calculation of all possible combinations of the order of the stages using the equations above. But, a quick, approximate method considers an infinite number of a single stage connected in cascade. This is called **noise measure** and is calculated using the equation of part C above to obtain

$$M = (F - 1)/(1 - 1/G).$$

Note that this is only approximate.

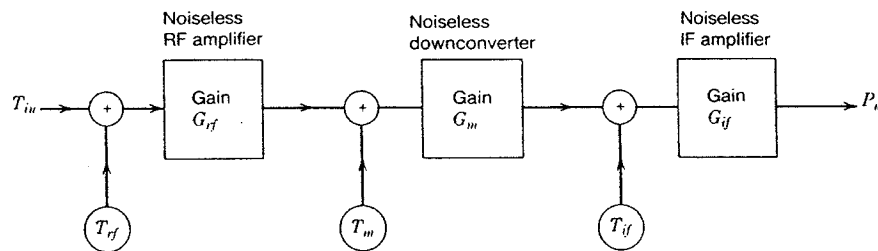

Equivalent noise generators

Figure 4.5a Equivalent circuit of receiver. The noisy amplifiers and downconverter have been replaced by noiseless units, with equivalent noise generators at their inputs.

9. Lossy elements - The use of lossy elements such as isolators or transmission lines requires that we know their gain and noise figure or noise temperature.

A. The gain is easy since gain is defined as

$$G = P_{OUT}/P_{IN};$$

$G < 1$ for lossy elements. Often the device is specified by loss, L , so that $G = 1/L$.

B. The noise figure is defined from thermodynamics principles as

$$T = (1 - G)T_P$$

where T_P is defined as the physical (or actual) temperature of the lossy element. Most often $T_P = T_0 = 290^\circ\text{K}$.

C. Lossy elements cost twice with regard to noise performance--the more loss, the greater the reduction of signal and the greater the noise contribution.

D. Whenever a lossy element is inserted in cascade before an amplifying element, the noise figure is greatly degraded due to the division by G_1 (a number less than 1) which increases the contribution to all two-ports which follow it in the cascade.

E. Propagation of waves through a lossy atmosphere also decrease the signal to noise ratio due to the same phenomenon.

10. Odds and ends

A. Theoretically, all stages from the antenna up to the detector are needed to calculate the output S/N. In fact, as one progresses through the cascaded system, the total gain of the first few sections will usually be enough to reduce the noise contribution of following sections to an insignificant level.

B. The overall system noise power is composed of the external noise introduced by the source or antenna and the internally generated noise. This can be expressed simply as

$$P_{SYS} = k(T_{ANT} + T_{EFF})B.$$

C. The effective input noise temperature is used to calculate the **noise floor** for the system,

$$P_N = kT_{EFF}B.$$

Input signals below this level will be "in the noise". Most often the source or antenna contribution is neglected in this calculation.

D. The narrower the bandwidth, the lower the noise floor.

E. **Tangential sensitivity** is defined as the signal level which is 3 dB more than the noise level, or twice the noise floor,

$$TSS = 2kT_{EFF}B.$$

F. Noise figure (and effective input noise temperature) shows a minimum which depends upon the bias currents of input stage transistors and upon the source impedance. Usually these considerations are "hidden" from the system user as they were designed into the LNA package.

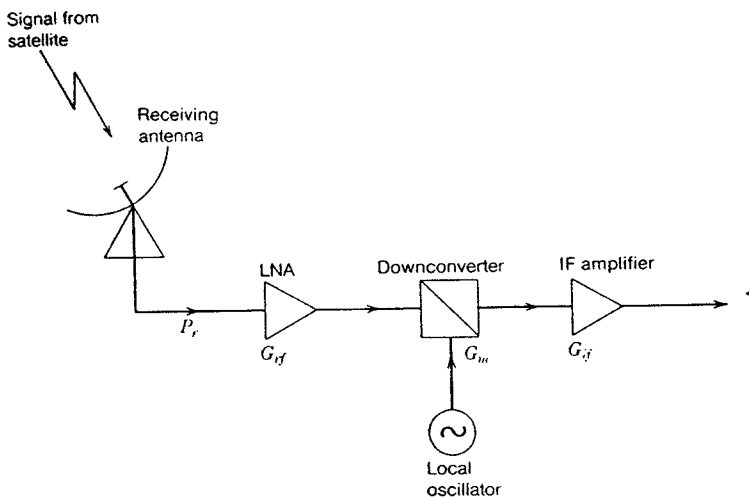

Figure 4.4 Earth station receiver.

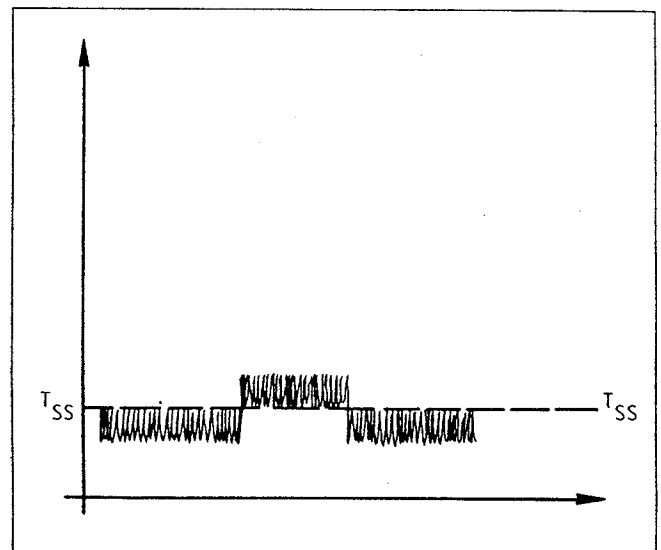

FIGURE 10. Oscilloscope Display to Determine T_{SS}