

Name \_\_\_\_\_ Mailbox \_\_\_\_\_

**ECE-320 Linear Control Systems**

**Spring 2016, Exam 1**

**No calculators or computers allowed, you may leave your answers as fractions.**

**Total** \_\_\_\_\_/100

Problems 1-3 (7 points) refer to the unit step response of a system, shown below

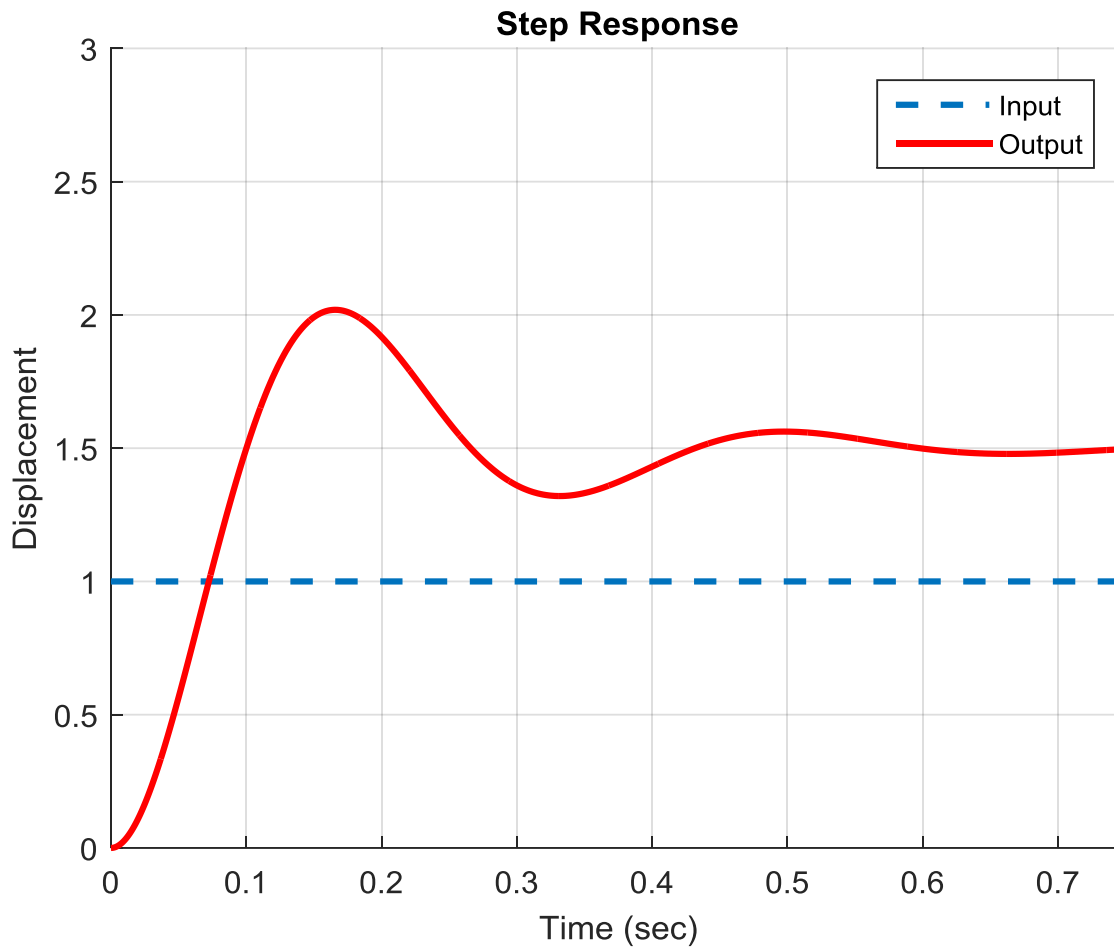

1) Estimate the steady state error

2) Estimate the percent overshoot

3) Estimate the static gain

4) (3 points) Estimate the steady state error for the ramp response of the system shown below:

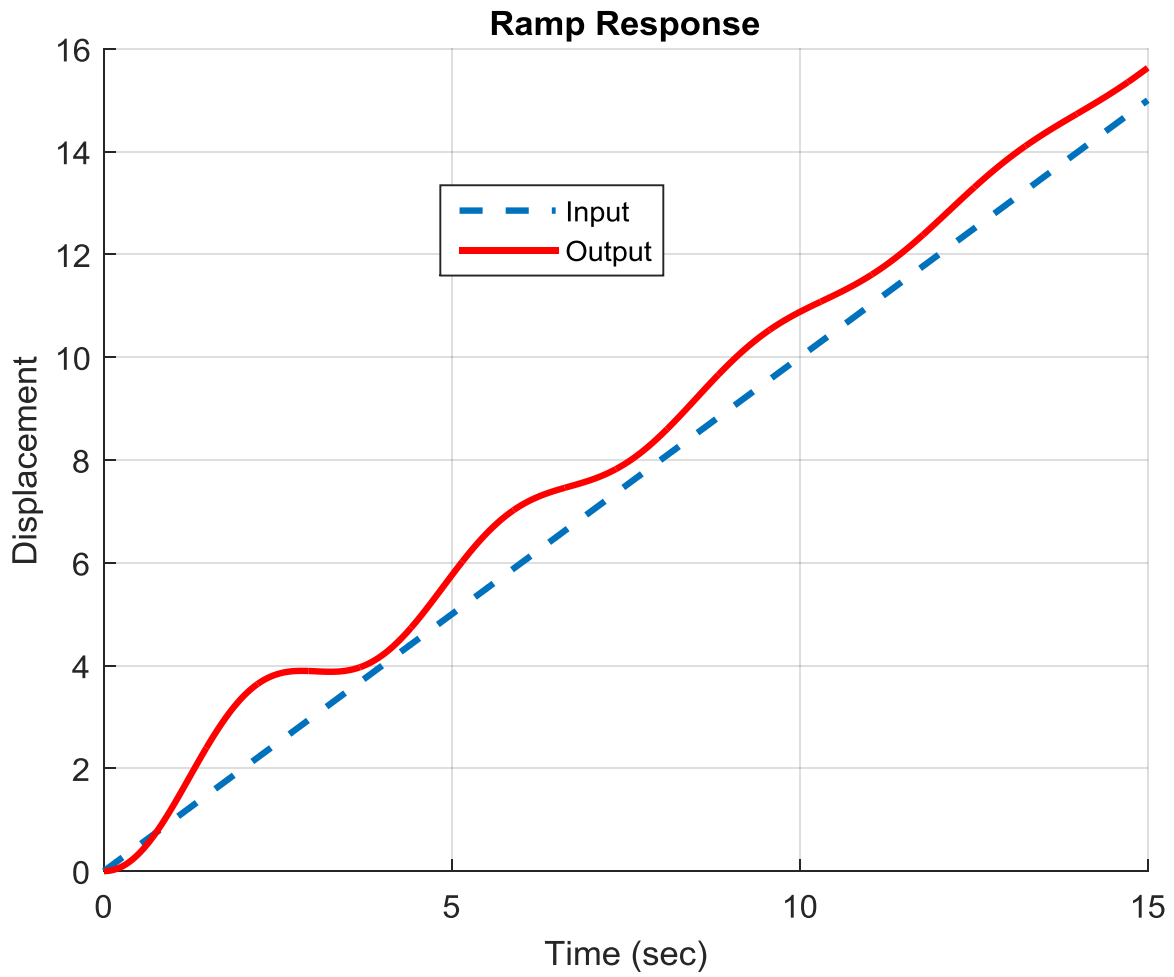

5) (10 points) For the block diagram shown below, determine a corresponding signal flow diagram and determine the closed loop transfer function

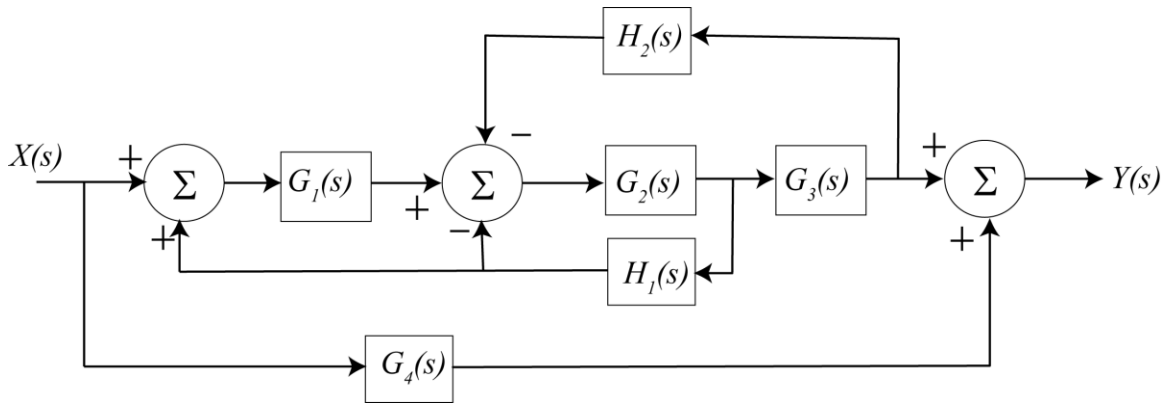

6) (5 points) Consider the following closed loop system, with plant  $G_p(s)$  and controller  $G_c(s)$ .

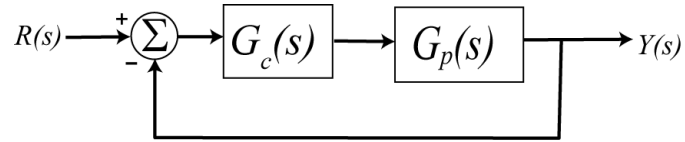

Let's assume that our **desired** closed loop transfer function,  $G_o(s)$ , our plant can be written in terms of numerators and denominators as

$$G_o(s) = \frac{N_o(s)}{D_o(s)} \quad G_p(s) = \frac{N_p(s)}{D_p(s)}$$

Our controller is then  $G_c(s) = \frac{N_o(s)D_p(s)}{N_p(s)[D_o(s) - N_o(s)]}$

a) Assuming the plant is given by  $G_p(s) = \frac{1}{s+1}$  and the desired closed loop transfer function is given

by  $G_o(s) = \frac{\omega_0^2}{s^2 + 1.4\omega_0s + \omega_0^2}$ , determine the controller

b) What is the resulting system type?

Problems 7-10 (8 points) refer to the following root locus plot (from *sisotool*)

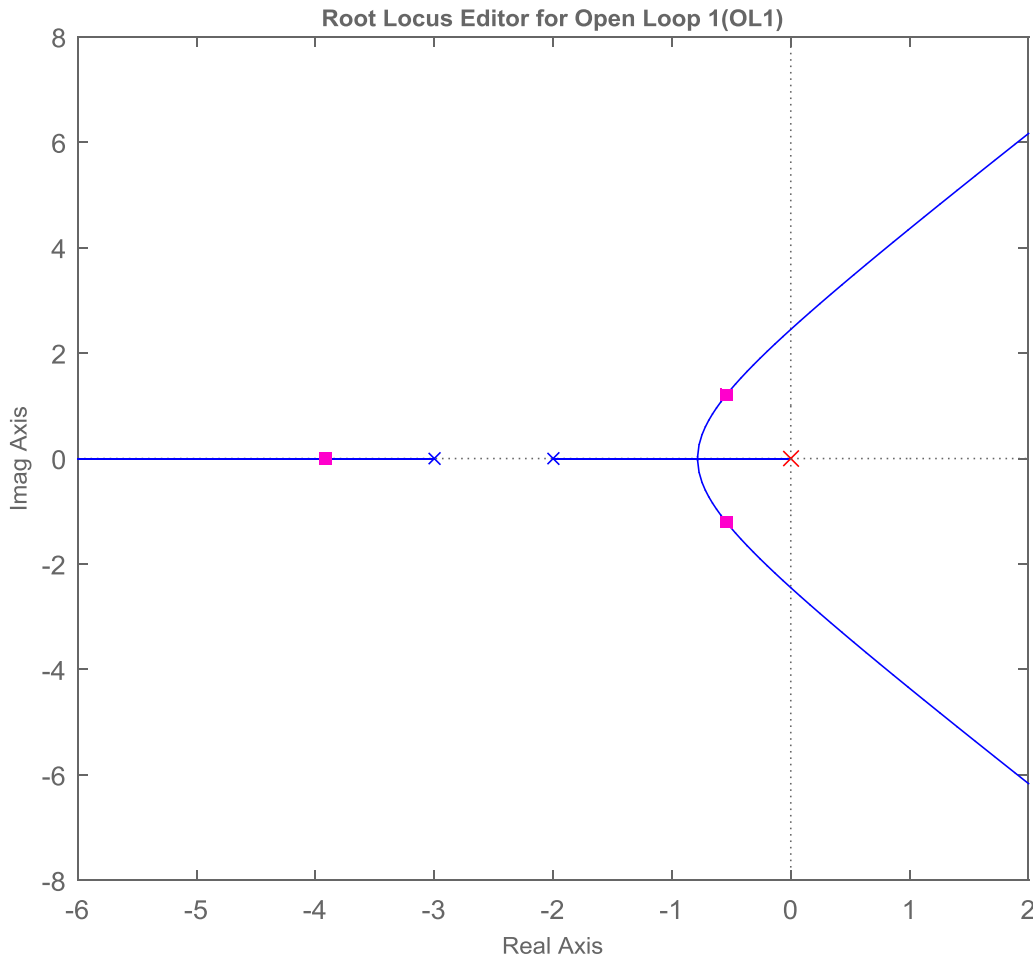

7) Is it possible for -6 to be a closed loop pole for this system ? (Yes or No)

8) When  $k$  (the varying parameter) is approximately 5 the poles are as shown in the figure. Estimate the settling time based on the closed loop pole locations alone.

9) Is this a type 1 system?

10) Will this system be stable for all values of  $k$ ?

**11) (5 points)** Consider a system with plant  $G_p(s) = \frac{1}{s+4}$  and controller  $G_c(s) = \frac{3.6(s^2 + 14.2s + 507)}{s}$ .

This information was entered into *sisotool*, as well as the constraint that the percent overshoot should be less than 20%. The corresponding root locus plot is shown below. With this information, are you guaranteed that the unit step response of the system with this root locus plot will have percent overshoot greater than or equal to 20%? Explain why you answered the way you did.

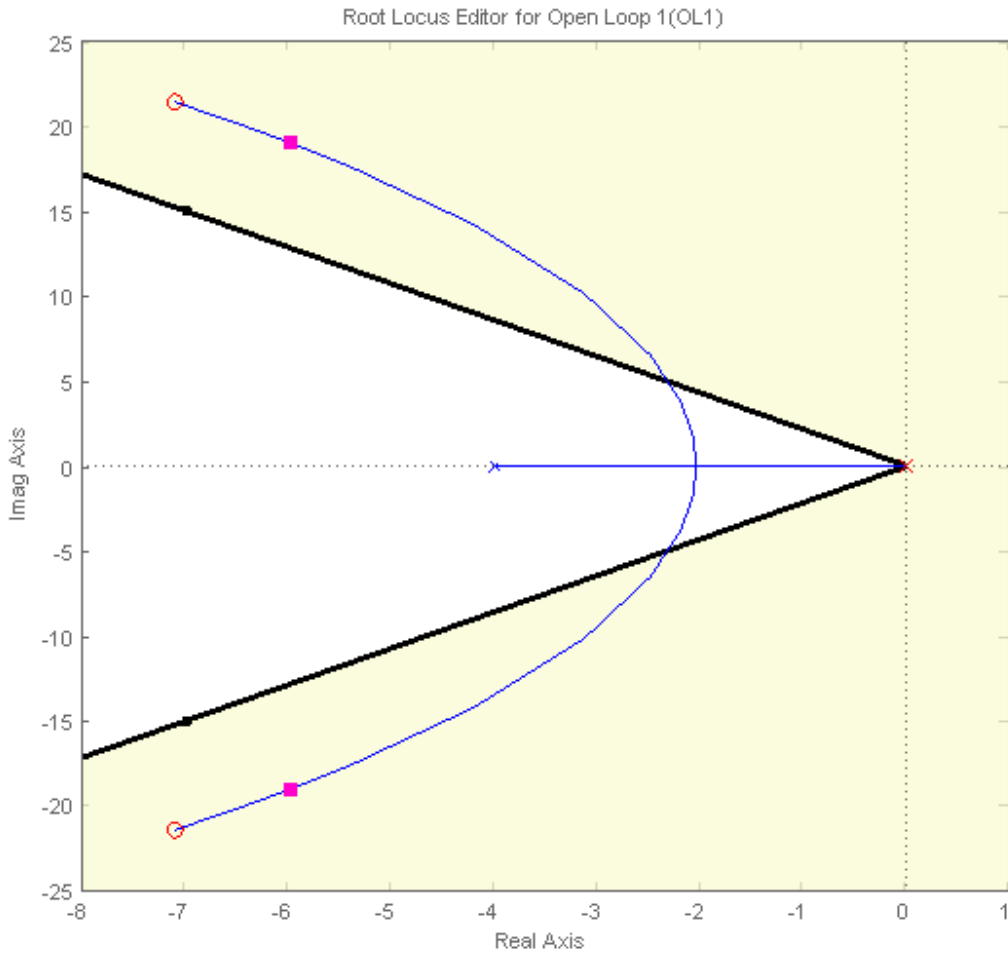

**12) (16 points)** For this problem assume the closed loop system below.

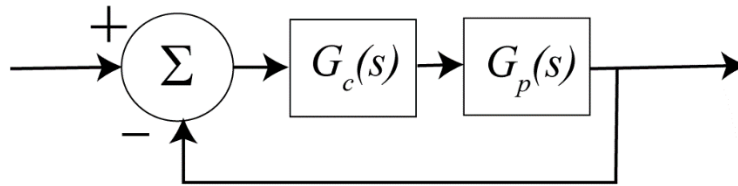

Assume  $G_p(s) = \frac{1}{(s+1+j)(s+1-j)}$

For each of the following problems you should sketch the root locus, and where necessary, compute the centroid of the asymptotes and the angles of the asymptotes. Be sure to indicate the direction along the root locus as the free parameter increases.

- a) Assume controller is a proportional controller,  $G_c(s) = k_p$
- b) Assume the controller is an integral controller,  $G_c(s) = \frac{k_i}{s}$
- c) Assume the controller is the PI controller  $G_c(s) = \frac{k(s+10)}{s}$
- d) Assume the controller is the PD controller  $G_c(s) = k(s+10)$



13) (16 points) For this problem assume the closed loop system below.

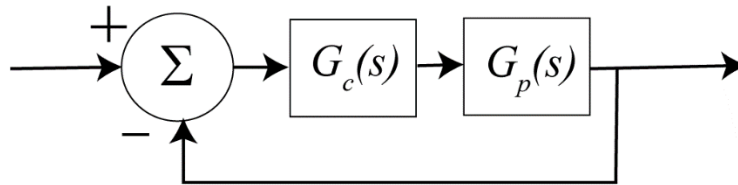

Assume  $G_p(s) = \frac{1}{(s+1)(s+2)}$

For each of the following problems you should sketch the root locus, and where necessary, compute the centroid of the asymptotes and the angles of the asymptotes. Be sure to indicate the direction along the root locus as the free parameter increases.

- a) Assume the controller is an integral controller,  $G_c(s) = \frac{k_i}{s}$
- b) Assume the controller is the PI controller  $G_c(s) = \frac{k(s+10)}{s}$
- c) Assume the controller is the PD controller  $G_c(s) = k(s+10)$
- d) Assume the controller is the PID controller  $G_c(s) = \frac{k(s+3+j)(s+3-j)}{s}$

Name \_\_\_\_\_ Mailbox \_\_\_\_\_

**14) (10 points)** Determine the *unit step response* of systems with transfer functions

a)  $H(s) = \frac{2}{(s+1)^2 + 2^2}$

b)  $H(s) = \frac{e^{-2s}}{(s+1)(s+2)}$

Name \_\_\_\_\_ Mailbox \_\_\_\_\_

**15) (10 points)** For impulse response  $h(n) = \left(\frac{1}{3}\right)^{n-1} u(n+1)$  and input  $x(n) = \left(\frac{1}{2}\right)^n u(n-2)$ , determine

the system output by evaluating the convolution sum  $y(n) = \sum_{k=-\infty}^{\infty} x(n-k)h(k)$

*You need to evaluate all sums, but you do not need to simplify your answers.*

Name \_\_\_\_\_

Mailbox \_\_\_\_\_

Name \_\_\_\_\_

Mailbox \_\_\_\_\_

Name \_\_\_\_\_

Mailbox \_\_\_\_\_

Name \_\_\_\_\_

Mailbox \_\_\_\_\_