

ECE-320: Linear Control Systems
Homework 1

Due: Tuesday December 9, 2014 *at the beginning of class*

1) For the following transfer functions, determine both the **impulse response** and the **unit step response**.

$$H(s) = \frac{s}{(s+1)(s+2)^2} \quad H(s) = \frac{1}{(2s+1)(3s+2)}$$

$$H(s) = \frac{2}{s^2 + 8s + 25} \quad H(s) = \frac{s+2}{s^2 + 2s + 4}$$

Scrambled Answers:

$$h(t) = \frac{2}{3} e^{-4t} \sin(3t)u(t), \quad h(t) = -e^{-t}u(t) + e^{-2t}u(t) + 2te^{-2t}u(t), \quad h(t) = e^{-t/2}u(t) - e^{-2t/3}u(t),$$

$$h(t) = e^{-t} \cos(\sqrt{3}t)u(t) + \frac{1}{\sqrt{3}} e^{-t} \sin(\sqrt{3}t)u(t), \quad y(t) = \frac{1}{2}u(t) - 2e^{-t/2}u(t) + \frac{3}{2}e^{-2t/3}u(t),$$

$$y(t) = \frac{1}{2}u(t) + \frac{1}{2\sqrt{3}} e^{-t} \sin(\sqrt{3}t)u(t) - \frac{1}{2} e^{-t} \cos(\sqrt{3}t)u(t), \quad y(t) = e^{-t}u(t) - e^{-2t}u(t) - te^{-2t}u(t),$$

$$y(t) = \frac{2}{25}u(t) - \frac{8}{75} e^{-4t} \sin(3t)u(t) - \frac{2}{25} e^{-4t} \cos(3t)u(t)$$

2) For the following transfer functions

$$H(s) = \frac{2}{s^2 + 2s + 2} \quad H(s) = \frac{3}{s^2 + 4s + 6} \quad H(s) = \frac{5}{s^2 + 6s + 10}$$

$$H(s) = \frac{4}{s^2 - 4s + 7} \quad H(s) = \frac{1}{s^2 + 4}$$

By computing the inverse Laplace transform show that the step responses are given by

$$y(t) = \left[1 - e^{-t} \cos(t) - e^{-t} \sin(t) \right] u(t) \quad y(t) = \left[\frac{1}{2} - \frac{1}{\sqrt{2}} e^{-2t} \sin(\sqrt{2}t) - \frac{1}{2} e^{-2t} \cos(\sqrt{2}t) \right] u(t)$$

$$y(t) = \left[\frac{1}{2} - \frac{3}{2} e^{-3t} \sin(t) - \frac{1}{2} e^{-3t} \cos(t) \right] u(t) \quad y(t) = \left[\frac{4}{7} + \frac{8\sqrt{3}}{21} e^{2t} \sin(\sqrt{3}t) - \frac{4}{7} e^{2t} \cos(\sqrt{3}t) \right] u(t)$$

$$y(t) = \left[\frac{1}{4} - \frac{1}{4} \cos(2t) \right] u(t)$$

3) (Mason's Rule) For the block diagram shown below, determine a corresponding signal flow diagram and show that the closed loop transfer function is

$$H_{system} = \frac{G_1 G_2 G_3 + G_4(1 - G_1 G_2 H_1 + G_2 H_1 + G_2 G_3 H_2)}{1 - G_1 G_2 H_1 + G_2 H_1 + G_2 G_3 H_2}$$

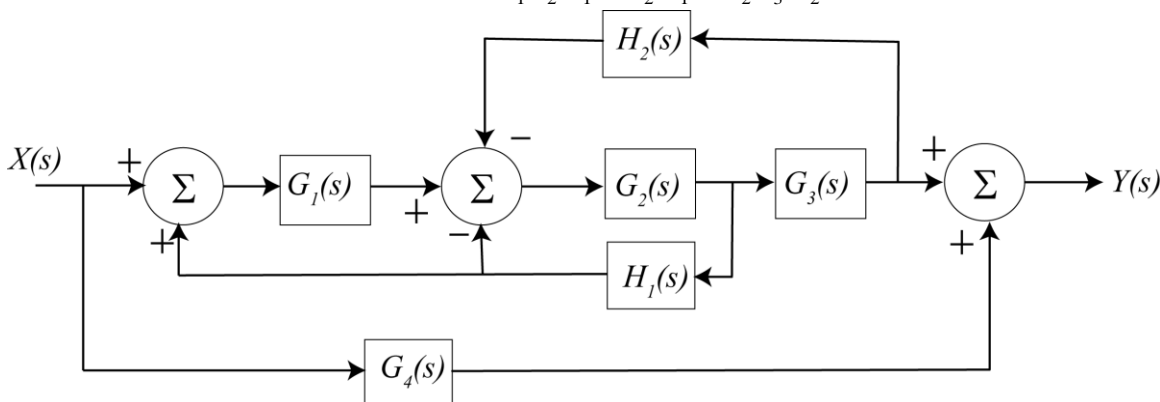

4) (Model Matching) Consider the following closed loop system, with plant $G_p(s)$ and controller $G_c(s)$.

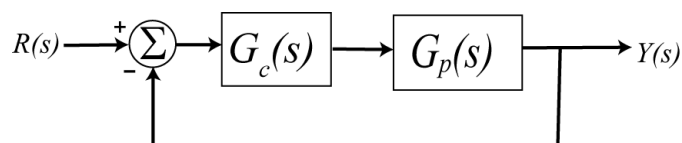

One way to choose the controller is to try and make your closed loop system match a transfer function that you choose (hence the name model matching). Let's assume that our **desired** closed loop transfer function, $G_o(s)$, our plant can be written in terms of numerators and denominators as

$$G_o(s) = \frac{N_o(s)}{D_o(s)} \quad G_p(s) = \frac{N_p(s)}{D_p(s)}$$

Show that our controller is then $G_c(s) = \frac{N_o(s)D_p(s)}{N_p(s)[D_o(s) - N_o(s)]}$

Note that there are some restrictions here, in that for implementation purposes the controller must be stable, and it must be proper.

5) For the following system, with plant $G_p(s) = \frac{1}{s+1}$, and controller $G_c(s)$

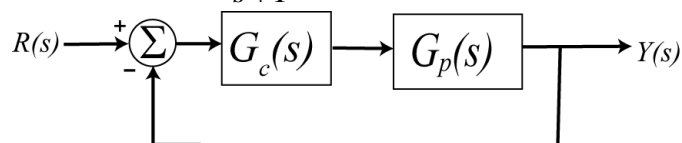

a) Using the results from problem 4, determine the controller so that the closed loop system matches a second order ITAE (Integral of Time and Absolute Error) optimal system, i.e., so that the closed loop transfer function is

$$G_0(s) = \frac{\omega_0^2}{s^2 + 1.4\omega_0 s + \omega_0^2}$$

Answer: $G_c(s) = \frac{\omega_0^2(s+1)}{s(s+1.4\omega_0)}$, note that there is a pole/zero cancellation between the controller and the plant and there is a pole at zero in the controller.

b) Show that the damping ratio for this system is 0.7, the closed loop poles of this system are at $-0.7\omega_0 \pm j0.714\omega_0$. For faster response should ω_0 be large or small?

c) Determine the controller so that the closed loop system matches a third order **deadbeat** system, i.e., so that the closed loop transfer function is

$$G_0(s) = \frac{\omega_0^3}{s^3 + 1.90\omega_0 s^2 + 2.20\omega_0^2 s + \omega_0^3}$$

Ans. $G_c(s) = \frac{\omega_0^3(s+1)}{s(s^2 + 1.9\omega_0 s + 2.20\omega_0^2)}$, note that there is a pole/zero cancellation between the controller and the plant and there is a pole at zero in the controller.

6) One of the methods that can be used to identify ζ and ω_n for mechanical systems the *log-decrement* method, which we will derive in this problem. If our system is at rest and we provide the mass with an initial displacement away from equilibrium, the response due to this displacement can be written

$$x_1(t) = Ae^{-\zeta\omega_n t} \cos(\omega_d t + \theta)$$

where

$x_1(t)$ = displacement of the mass as a function of time

ζ = damping ratio

ω_n = natural frequency

ω_d = damped frequency = $\omega_n \sqrt{1 - \zeta^2}$

After the mass is released, the mass will oscillate back and forth with period given by $T_d = \frac{2\pi}{\omega_d}$, so if we measure

the period of the oscillation (T_d) we can estimate ω_d . Let's assume t_0 is the time of one peak of the cosine. Since the cosine is periodic, subsequent peaks will occur at times given by $t_n = t_0 + nT_d$, where n is an integer.

a) Show that

$$\frac{x_1(t_0)}{x_1(t_n)} = e^{\zeta\omega_n T_d n}$$

b) If we define the log decrement as

$$\delta = \ln \left[\frac{x_1(t_0)}{x_1(t_n)} \right]$$

show that we can compute the damping ratio as

$$\zeta = \frac{\delta}{\sqrt{4n^2\pi^2 + \delta^2}}$$

c) Given the initial condition response shown in the Figures on the next page, estimate the damping ratio and natural frequency using the log-decrement method. (You should get answers that include the numbers 15, 0.2, 0.1 and 15, approximately.)

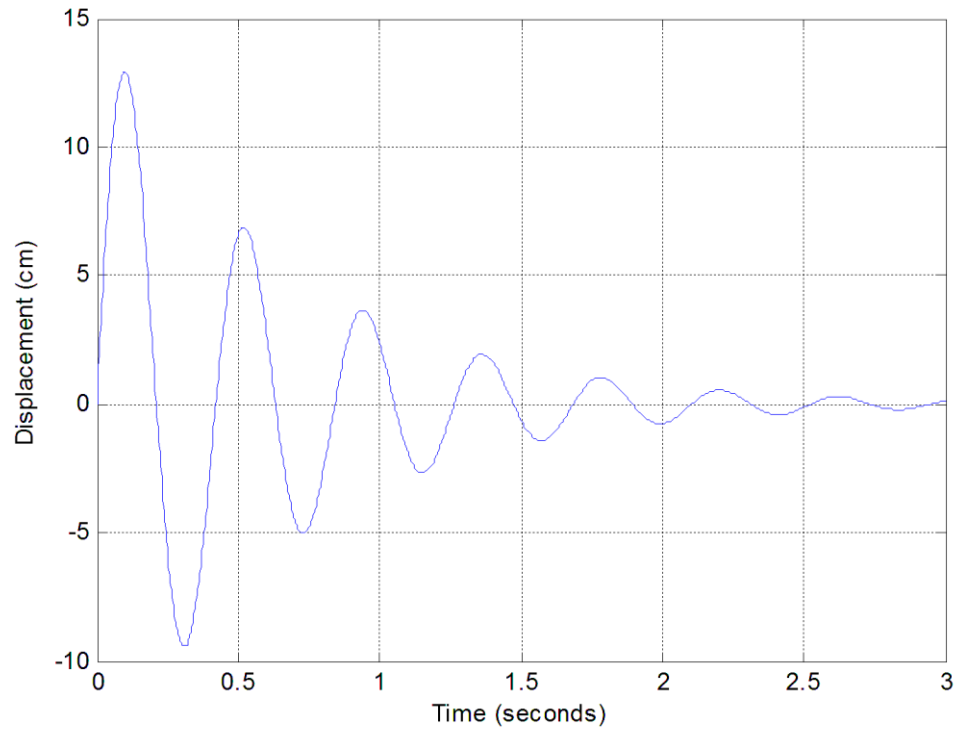

Figure 1. Initial condition response for second order system A.

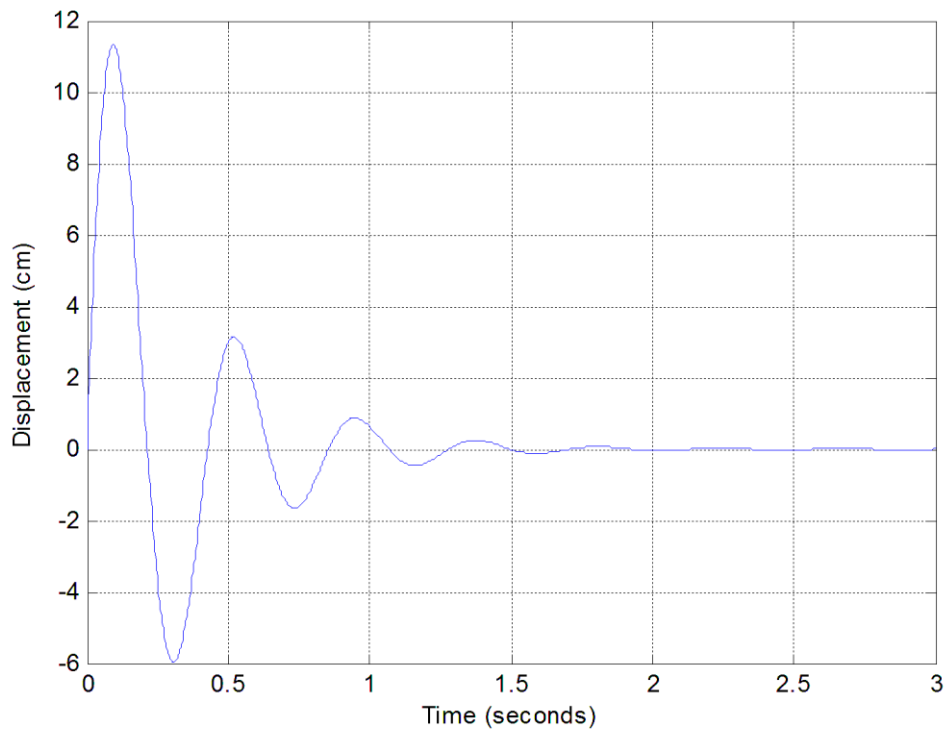

Figure 2. Initial condition response for second order system.

7) (Matlab/Simulink) Download and unzip the files from the class website. The file **closedloop.slx** is a Simulink file for a simple closed loop system, as shown below in Figure 1.

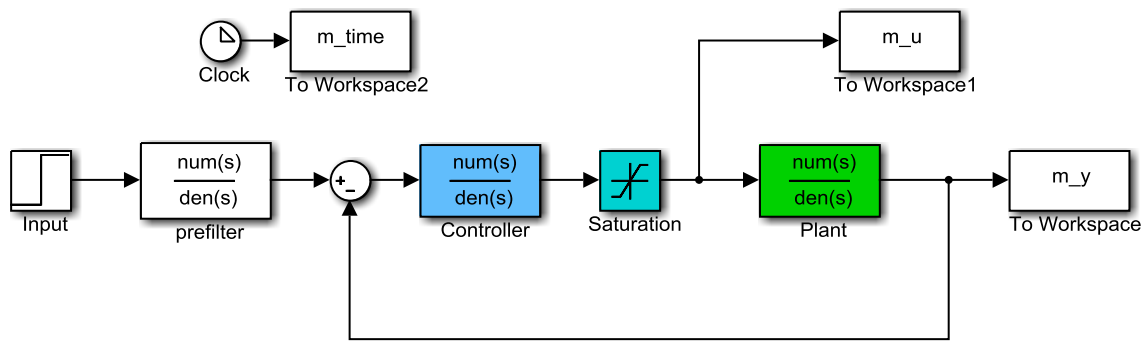

Figure 1. Simple feedback control system

In this system the plant is the thing we want to control, the controller modifies the behavior of the plant, and we have included a limit on the control effort (the Saturation block). Many real systems have limits on the control effort, as you will see.

The file **closedloop_driver.m** is the Matlab driver file that loads parameters and transfer functions into the Matlab workspace for the Simulink file to use. Using these two programs we can look at some model matching systems and some examples of what happens when the model does not match the real system. Also this gives us a review of Matlab and Simulink.

If you run the programs as they are you should get a response like that shown in Figure 2 on the next page. This figure shows the response to the plant (the thing we want to control) in the top graph. The middle graph shows a control system using model matching for a 1 cm input. In this graph the red line shows the response of the closed loop transfer function we expect to get if the mathematical model of the plant is exact, and the blue line shows the results using the model matching control system. You should note that the control system has a faster response, smaller overshoot, and a steady state error of zero (the output is equal to the input in steady state). The last graph shows the control effort of the system. Most practical systems (like op amps) tend to saturate.

- a) Modify the parameter ω_0 to get the fastest response you can without saturating the control effort (the control effort should remain below 2). Note that the control effort is maximum at the beginning and then dies down, this is common for controllers. At this point our model of the plant and the true plant have the transfer

$$\text{function } G_p(s) = \frac{100}{s^2 + 2s + 10}. \text{ Turn in your graph.}$$

In the next few parts we will look at examples when the model is not matched exactly. For each of these parts use the value of ω_0 you determined in part a.

- b) Assume the true plant has the transfer function $G_p(s) = \frac{20}{s^2 + s + 20}$. This involves changing num_Gp and den_Gp, the rest of the code you leave alone. Rerun the simulation and turn in your results. You should notice that the model matching controller does not follow the ideal (the red model in the graph), but it does eventually converge to a system with zero steady state error. Turn in your graph.

- c) Assume the true plant has the transfer function $G_p(s) = \frac{25s + 50}{s^2 + s + 20}$. Rerun the simulation and turn in your results.
- d) Assume the true plant has the transfer function $G_p(s) = \frac{100}{0.1s^3 + s^2 + s + 20}$. Rerun the simulation and turn in your results.
- e) Assume the true plant has the transfer function $G_p(s) = \frac{100}{s^2 - 2s - 20}$. Set the final time to 3.5 seconds ($T_f = 3.5$) and rerun the simulation and turn in your results. What happens in this case?

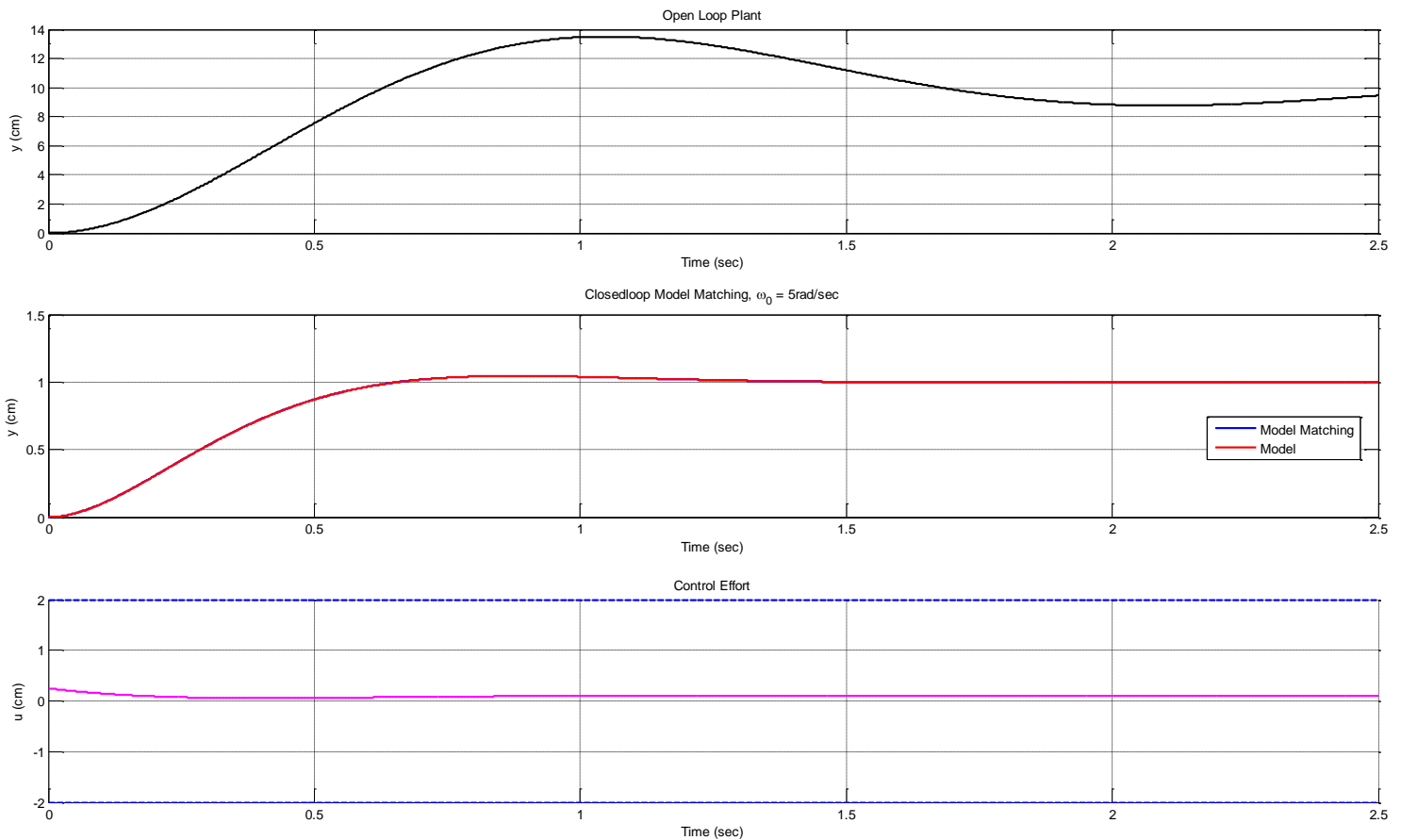

Figure 2. Response of a plant and an ITAE closedloop model matching system.