

ECE-205 : Dynamical Systems

Homework #3

Due : **Tuesday** March 23 at the beginning of class

Exam 1, Thursday March 25th

1) For this problem, consider six second order systems described by the following differential equations:

$$\ddot{y}(t) + 9\dot{y}(t) + 20y(t) = 20Kx(t)$$

$$\ddot{y}(t) + 10\dot{y}(t) + 25y(t) = 25Kx(t)$$

$$\ddot{y}(t) + 4\dot{y}(t) + 13y(t) = 13Kx(t)$$

$$\ddot{y}(t) + 6\dot{y}(t) + 8y(t) = 8Kx(t)$$

$$\ddot{y}(t) + 6\dot{y}(t) + 9y(t) = 9Kx(t)$$

$$\ddot{y}(t) + 6\dot{y}(t) + 13y(t) = 13Kx(t)$$

a) Assume the systems are initially at rest and input is a step, $x(t) = Au(t)$, determine expressions for the system output by finding the forced and unforced responses and then solving for the unknown coefficients just as we did in class.

b) For the systems with real roots, show that your solution meets the two initial conditions ($y(0) = \dot{y}(0) = 0$). For the systems with complex roots, determine ζ and ω_n from the governing differential equation, and show that your solution agrees with the form

$$y(t) = KA \left[1 - \frac{1}{\sqrt{1-\zeta^2}} \right] e^{-\zeta\omega_n t} \sin(\omega_d t + \theta) \quad \theta = \cos^{-1}(\zeta) \quad \omega_d = \omega_n \sqrt{1-\zeta^2}$$

Do not assume this is the form of the solution, but use it to check your answer.

Answers:

$$y(t) = KA - 5KAe^{-4t} + 4KAe^{-5t}$$

$$y(t) = KA - KAe^{-5t} - 5KAte^{-5t}$$

$$y(t) = KA[1 - 1.202e^{-2t} \sin(3t + 56.3^\circ)]$$

$$y(t) = KA + KAe^{-4t} - 2KAe^{-2t}$$

$$y(t) = KA - KAe^{-3t} - 3KAte^{-5t}$$

$$y(t) = KA[1 - 1.803e^{-3t} \sin(2t + 33.7^\circ)]$$

2) The response of a second order system is

$$y(t) = 1 - 1.0050e^{-t} \sin(9.9500t + 1.4706 \text{ rad})$$

a) Take the derivative of this function to determine the time at which the maximum occurs (the time to peak)

b) Determine the maximum value of this function (the value at the time to peak)

c) Determine the percent overshoot using your answer to (b)

d) For this response determine ζ , ω_d , and ω_n

e) Compute the percent overshoot using the formula

$$PO = e^{-\frac{\zeta\pi}{\sqrt{1-\zeta^2}}} \times 100\%$$

and verify your answer to c.

3) The response of a second order system is

$$y(t) = 2[1 - 1.0328e^{-3.75t} \sin(14.5237t + 1.3181 \text{ rad})]$$

a) Take the derivative of this function to determine the time at which the maximum occurs (the time to peak)

b) Determine the maximum value of this function (the value at the time to peak)

c) Determine the percent overshoot using your answer to (b)

d) For this response determine ζ , ω_d , and ω_n

e) Compute the percent overshoot using the formula

$$PO = e^{-\frac{\zeta\pi}{\sqrt{1-\zeta^2}}} \times 100\%$$

and verify your answer to c.

4) One of the methods that can be used to identify ζ and ω_n for mechanical systems the *log-decrement* method, which we will derive in this problem. If our system is at rest and we provide the mass with an initial displacement away from equilibrium, the response due to this displacement can be written

$$x_1(t) = Ae^{-\zeta\omega_n t} \cos(\omega_d t + \theta)$$

where

$x_1(t)$ = displacement of the mass as a function of time

ζ = damping ratio

ω_n = natural frequency

ω_d = damped frequency = $\omega_n \sqrt{1 - \zeta^2}$

After the mass is released, the mass will oscillate back and forth with period given by $T_d = \frac{2\pi}{\omega_d}$, so if we

measure the period of the oscillation (T_d) we can estimate ω_d . Let's assume t_0 is the time of one peak of the cosine. Since the cosine is periodic, subsequent peaks will occur at times given by $t_n = t_0 + nT_d$, where n is an integer.

a) Show that

$$\frac{x_1(t_0)}{x_1(t_n)} = e^{\zeta\omega_n T_d n}$$

b) If we define the log decrement as

$$\delta = \ln \left[\frac{x_1(t_0)}{x_1(t_n)} \right]$$

show that we can compute the damping ratio as

$$\zeta = \frac{\delta}{\sqrt{4n^2\pi^2 + \delta^2}}$$

c) Given the initial condition response shown in the Figures on the next page, estimate the damping ratio and natural frequency using the log-decrement method. (You should get answers that include the numbers 15, 0.2, 0.1 and 15, approximately.)

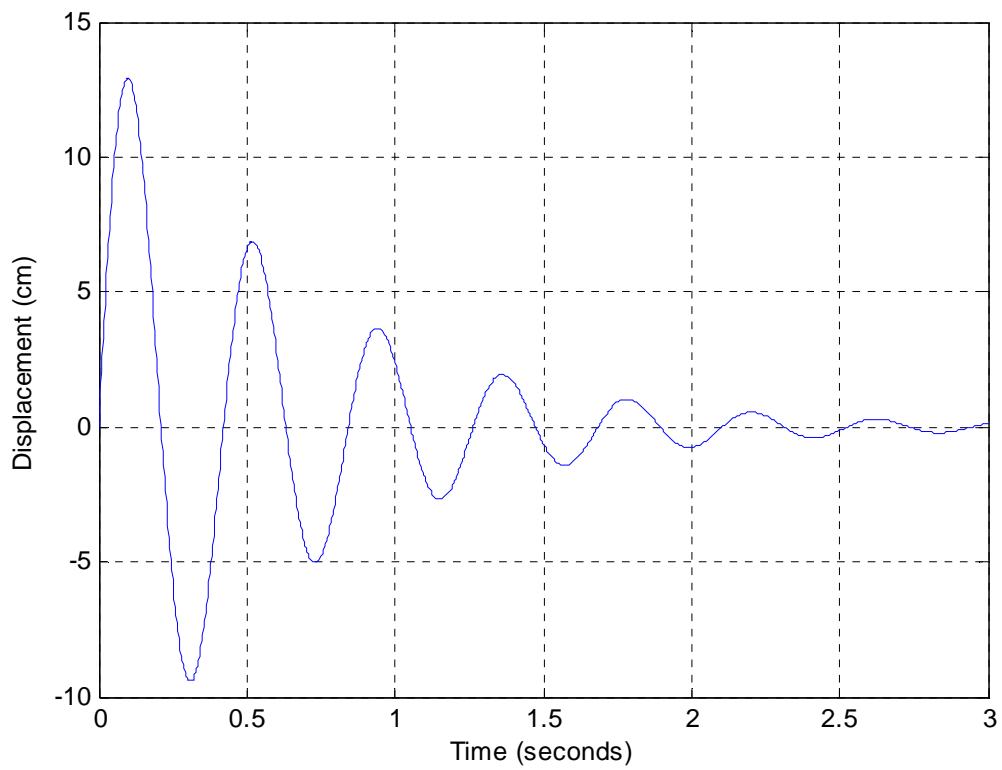

Figure 1. Initial condition response for second order system A.

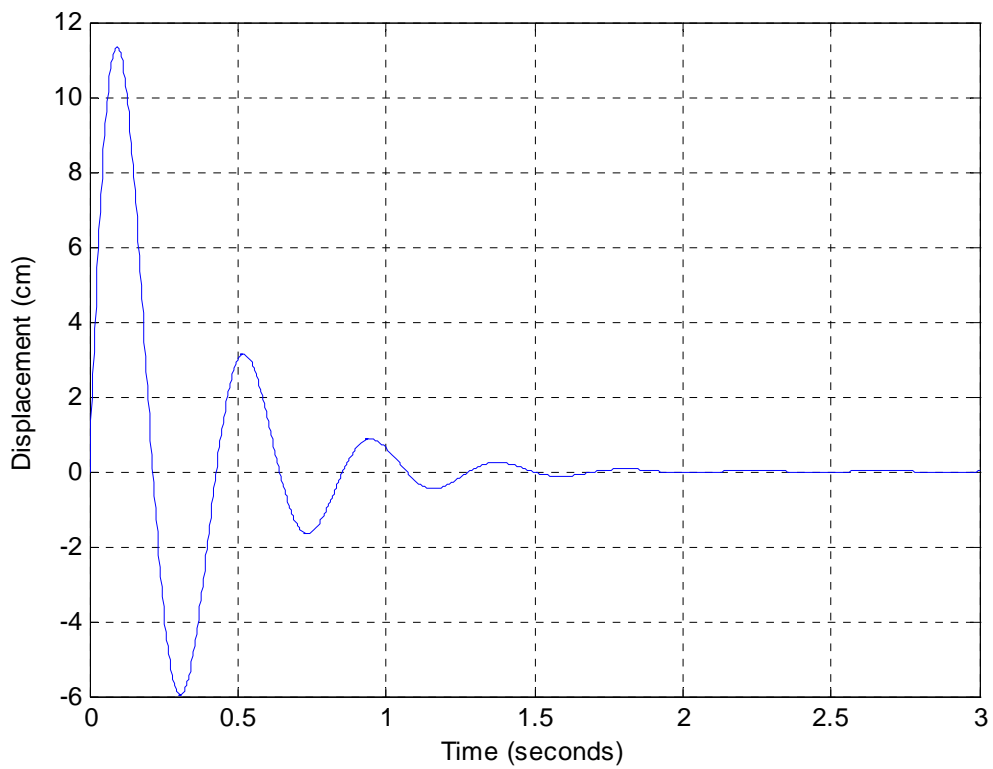
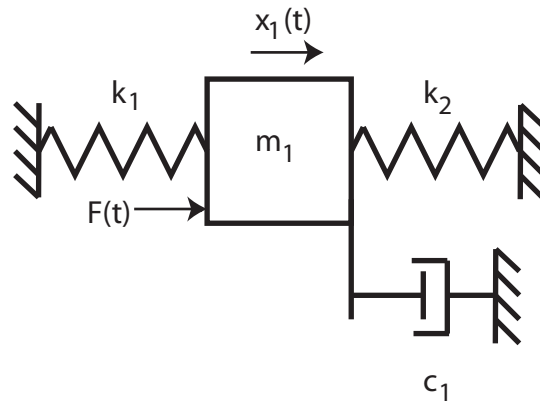

Figure 2. Initial condition response for second order system B.

5) (Prelab) Consider the following one degree of freedom system we will be utilizing this term:



a) Draw a freebody diagram of the forces on the mass.

b) Show that the equations of motion can be written:

$$m_1 \ddot{x}_1(t) + c_1 \dot{x}_1(t) + (k_1 + k_2)x_1(t) = F(t)$$

or

$$\frac{1}{\omega_n^2} \ddot{x}_1(t) + \frac{2\zeta}{\omega_n} \dot{x}_1(t) + x_1(t) = KF(t)$$

c) What are the damping ratio ζ , the natural frequency ω_n , and the static gain K in terms of m_1 , k_1 , k_2 , and c_1 ?