

1.0 Electrical Systems

The types of dynamical systems we will be studying can be modeled in terms of algebraic equations, differential equations, or integral equations. We will begin by looking at familiar mathematical models of ideal resistors, ideal capacitors, and ideal inductors. Then we will begin putting these models together to develop models for RL and RC circuits. Finally, we will review solution techniques for the first order differential equation we derive to model the systems.

1.1 Ideal Resistors

The governing equation for a resistor with resistance R is given by Ohm's law,

$$v(t) = Ri(t)$$

where $v(t)$ is the voltage across the resistor and $i(t)$ is the current through the resistor. Here R is measured in Ohms, $v(t)$ is measured in volts, and $i(t)$ is measured in amps. The entire expression must be in volts, so we get the unit expression

$$[\text{volts}] = [\text{Ohms}][\text{amps}]$$

1.2 Ideal Capacitors

The governing equation for a capacitor with capacitance C is given by

$$i(t) = C \frac{dv(t)}{dt}$$

Here C is measured in farads, and again $v(t)$ is measured in volts and $i(t)$ is measured in amps. This expression also helps us with the units. The entire expression must be in terms of current, so looking at the differential relationship we can determine the unit expression

$$[\text{amps}] = [\text{farads}][\text{volts}]/[\text{seconds}]$$

We can integrate this equation from an initial time t_0 up to the current time t as follows:

$$i(t) = C \frac{dv(t)}{dt}$$
$$\frac{1}{C} i(t) dt = dv(t)$$

Next, since we want to integrate up to a final time t , we need to use a dummy variable in the integral that is not t . This is an important habit to get into—do not use t as the dummy variable of integration if we expect a function of time as the output! Here we have chosen to use the dummy variable λ . Also we incorporate the fact that at time t_0 the voltage is $v(t_0)$, while at time t the voltage is $v(t)$

$$\frac{1}{C} \int_{t_0}^t i(\lambda) d\lambda = \int_{v(t_0)}^{v(t)} dv(\lambda)$$

Carrying out the integration we get

$$\frac{1}{C} \int_{t_0}^t i(\lambda) d\lambda = v(t) - v(t_0)$$

which we can rearrange as

$$v(t) = v(t_0) + \frac{1}{C} \int_{t_0}^t i(\lambda) d\lambda$$

This expression tells us there are two components to the voltage across a capacitor, the initial voltage $v(t_0)$ and the part due to any current flowing through the capacitor after that time, $\frac{1}{C} \int_{t_0}^t i(\lambda) d\lambda$

Finally, these expressions help us determine some important characteristics of our ideal capacitor:

- If the voltage across the capacitor is constant, then the current through the capacitor must be zero since the current is proportional to the rate of change of the voltage. Hence, *a capacitor is an open circuit to dc.*
- *It is not possible to change the voltage across a capacitor in zero time.* The voltage across a capacitor must be a continuous function of time, otherwise an infinite amount of current would be required.

1.3 Ideal Inductors

The governing equation for an inductor with inductance L is given by

$$v(t) = L \frac{di(t)}{dt}$$

Here L is measured in henrys, and again $v(t)$ is measured in volts and $i(t)$ is measured in amps. This expression also helps us with the units. The entire expression must be in terms of voltage, so looking at the differential relationship we can determine the unit expression

$$[\text{volts}] = [\text{henrys}][\text{amps}]/[\text{seconds}]$$

We can integrate this equation from an initial time t_0 up to the current time t as follows:

$$v(t) = L \frac{di(t)}{dt}$$

$$\frac{1}{L} v(t) dt = di(t)$$

Next, since we want to integrate up to a final time t , so we again have chosen to use the dummy variable λ . Also we incorporate the fact that at time t_0 the current is, $i(t_0)$ while at time t the current is $i(t)$.

$$\frac{1}{L} \int_{t_0}^t v(\lambda) d\lambda = \int_{i(t_0)}^{i(t)} di(\lambda)$$

Carrying out the integration we get

$$\frac{1}{L} \int_{t_0}^t v(\lambda) d\lambda = i(t) - i(t_0)$$

which we can rearrange as

$$i(t) = i(t_0) + \frac{1}{L} \int_{t_0}^t v(\lambda) d\lambda$$

This expression tells us there are two components to the current through an inductor, the initial current $i(t_0)$ and the part due to any voltage across the inductor after that time, $\frac{1}{L} \int_{t_0}^t v(\lambda) d\lambda$.

Finally, these expressions help us determine some important characteristics of our ideal inductor:

- If the current through an inductor is constant, then the voltage across the inductor must be zero since the voltage is proportional to the rate of change of the current. Hence, *an inductor is a short circuit to dc.*
- *It is not possible to change the current through an inductor in zero time.* The current through an inductor must be a continuous function of time, otherwise an infinite amount of voltage would be required.

2.0 First Order Circuits

A first order circuit is a circuit with one effective energy storage element, either an inductor or a capacitor. (In some circuits it may be possible to combine multiple capacitors or inductors into one equivalent capacitor or inductor.) We begin this section with the derivation of the governing differential equation for various first order circuits. We will then put the first order equation into a standard form that allows us to easily determine physical characteristics of the circuit. Next we show an alternative method for checking some parts of the governing differential equations. We then solve the differential equations for the case of piecewise constant inputs, and finish the section with an alternative method of solving the differential equations using integrating factors.

2.1 Governing Differential Equations for First Order Circuits

In this section we derive the governing differential equations that model various RL and RC circuits. We then put the governing first order differential equations into a standard form, which allows us to read off descriptive information about the system very easily. The standard form we will use is

$$\tau \frac{dy(t)}{dt} + y(t) = Kx(t)$$

Here we assume the *system input* is $x(t)$ and the *system output* is $y(t)$. τ is the system *time constant*, which indicates how long it will take the system to reach steady state for a step (constant) input. K is the *static gain* of the system. For a constant input of amplitude A ($x(t) = Au(t)$, where $u(t)$ is the unit step function), in steady state we have $\frac{dy(t)}{dt} = 0$ and $y(t) = Kx(t) = KA$. Hence the static gain lets us easily compute the steady state value of the output. For circuits with capacitors the differential equation will in general be in terms of a voltage (the output $y(t)$ will be a voltage), while for circuits with inductors the differential equation will in general be in terms of current (the output $y(t)$ will be a current).

Example 2.1.1. Consider the RC circuit shown in Figure 2.1. The voltage source is $v_s(t)$. We start to derive the governing differential equation by determining the single current in the loop

$$i_R(t) = \frac{v_s(t) - v_c(t)}{R} = i_C(t) = C \frac{dv_c(t)}{dt}$$

or

$$C \frac{dv_c(t)}{dt} = \frac{v_s(t) - v_c(t)}{R}$$

where $v_c(t)$ is the voltage across the capacitor and the current in the loop is equal to the current through the resistor $i_R(t)$ and the current through the capacitor $i_C(t)$. We can put this into a more standard form by rearranging the terms

$$RC \frac{dv_c(t)}{dt} + v_c(t) = v_s(t)$$

If we define the *time constant* $\tau = RC$, then we have

$$\tau \frac{dv_c(t)}{dt} + v_c(t) = v_s(t)$$

Here the static gain $K = 1$.

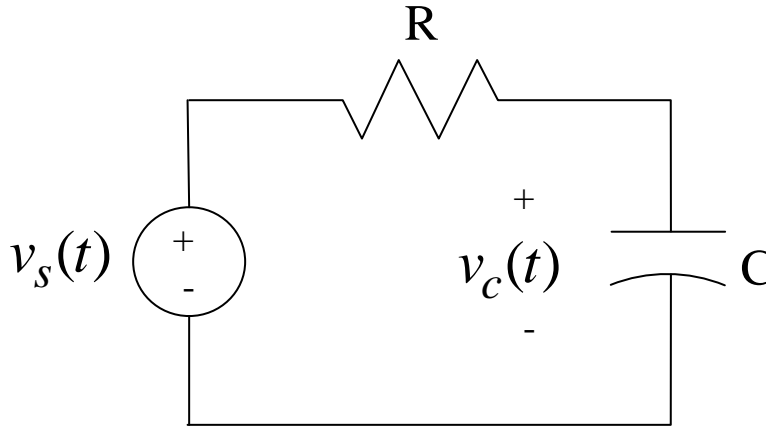

Figure 2.1. Circuit for Example 2.1.1.

Example 2.1.2. Consider the RC circuit shown in Figure 2.2. Again the voltage source is $v_s(t)$. We again start to derive the governing differential equation by determining the current through resistor R_a ,

$$i(t) = \frac{v_s(t) - v_c(t)}{R_a}$$

This current must be equal to the sum of the currents through the capacitor and R_b ,

$$i(t) = \frac{v_c(t)}{R_b} + C \frac{dv_c(t)}{dt}$$

Equating these we get the governing differential equation:

$$i(t) = \frac{v_s(t) - v_c(t)}{R_a} = \frac{v_c(t)}{R_b} + C \frac{dv_c(t)}{dt}$$

Rearranging terms we get

$$C \frac{dv_c(t)}{dt} + \left(\frac{1}{R_a} + \frac{1}{R_b} \right) v_c(t) = \frac{1}{R_a} v_s(t)$$

$$C \frac{dv_c(t)}{dt} + \frac{R_a + R_b}{R_a R_b} v_c(t) = \frac{1}{R_a} v_s(t)$$

or

$$\frac{R_a R_b C}{R_a + R_b} \frac{dv_c(t)}{dt} + v_c(t) = \frac{R_b}{R_a + R_b} v_s(t)$$

With time constant $\tau = \frac{R_a R_b C}{R_a + R_b}$ and static gain $K = \frac{R_b}{R_a + R_b}$ we get

$$\tau \frac{dv_c(t)}{dt} + v_c(t) = K v_s(t)$$

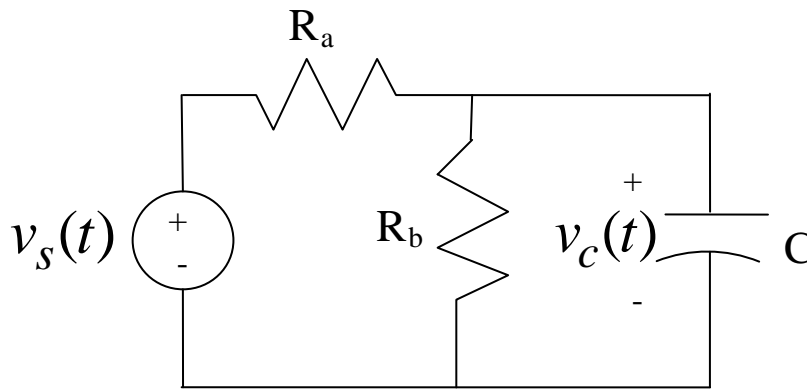

Figure 2.2. Circuit used in Example 2.1.2.

Example 2.1.3. Consider the operational-amplifier circuit shown in Figure 2.3. The input voltage is again $v_s(t)$ and the output voltage (the voltage across the load resistor R_L) is the same as the voltage across the capacitor (since the + terminal of the op amp is assumed to be grounded). We will assume an ideal op amp, which implies the conditions

$$i^+(t) = i^-(t) = 0$$

$$v^+(t) = v^-(t)$$

Let's look at the currents flowing into the negative (feedback) terminal of the op-amp using the ideal op-amp model. Since for our example the non-inverting terminal is tied to ground we have $v^+(t) = 0$. With these assumptions our governing differential equation becomes

$$0 = \frac{v_s(t)}{R_a} + \frac{v_c(t)}{R_b} + C \frac{dv_c(t)}{dt}$$

Rearranging this gives

$$C \frac{dv_c(t)}{dt} + \frac{v_c(t)}{R_b} = -\frac{v_s(t)}{R_a}$$

or

$$R_b C \frac{dv_c(t)}{dt} + v_c(t) = -\frac{R_b}{R_a} v_s(t)$$

Setting the time constant $\tau = R_b C$ and static gain $K = -\frac{R_b}{R_a}$ we finally have

$$\tau \frac{dv_c(t)}{dt} + v_c(t) = K v_s(t)$$

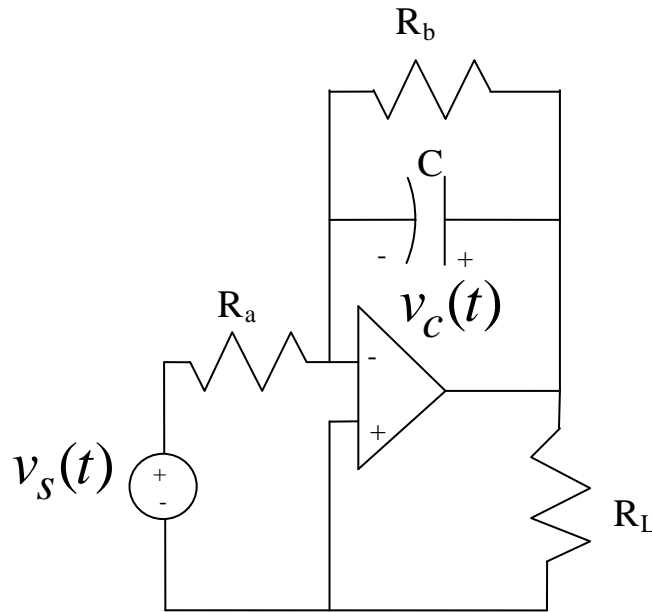

Figure 2.3. Circuit for Example 2.1.3.

Example 2.1.4. Consider the RL circuit shown in Figure 2.4. The single current in the loop is given by

$$i(t) = \frac{v_s(t) - v_L(t)}{R}$$

where

$$v_L(t) = L \frac{di(t)}{dt}$$

Combining and rearranging we get

$$L \frac{di(t)}{dt} + Ri(t) = v_s(t)$$

or

$$\frac{L}{R} \frac{di(t)}{dt} + i(t) = \frac{1}{R} v_s(t)$$

With time constant $\tau = \frac{L}{R}$ and static gain $K = \frac{1}{R}$ the governing differential equation is

$$\tau \frac{di(t)}{dt} + i(t) = K v_s(t)$$

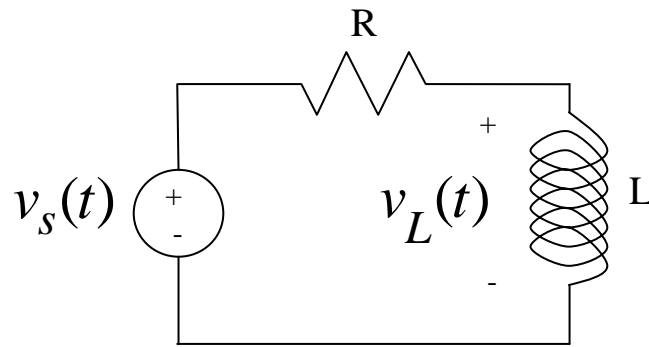

Figure 2.4. Circuit for Example 2.1.4.

Example 2.1.5. Consider the RC circuit shown in Figure 2.5. The single current source must be divided between the current flowing through resistor R_b and the current flowing through the capacitor C ,

$$i_s(t) = \frac{v_c(t)}{R_b} + C \frac{dv_c(t)}{dt}$$

Rearranging we get

$$R_b C \frac{dv_c(t)}{dt} + v_c(t) = R_b i_s(t)$$

With time constant $\tau = R_b C$ and static gain $K = R_b$ the governing differential equation is

$$\tau \frac{dv_c(t)}{dt} + v_c(t) = K i_s(t)$$

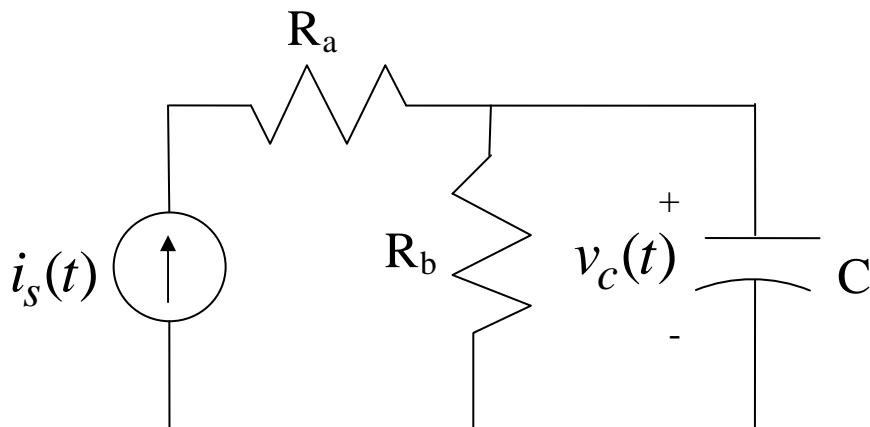

Figure 2.5. Circuit used in Example 2.1.5.

2.2 Thevenin Resistance, Time Constants, and Static Gain

Although we are focusing our attention on deriving the governing equations for first order circuits, it is useful and very convenient to be able to check our equations as much as possible.

First of all, for first order RC circuits the time constants will be of the form $\tau = R_{th} C_{eq}$ where R_{th} is the Thevenin resistance seen from the ports of the equivalent capacitor, C_{eq} . For first order RL circuits the time constants will

be of the form $\tau = \frac{L_{eq}}{R_{th}}$ where R_{th} is the Thevenin resistance seen from the ports of the equivalent inductor, L_{eq} .

Recall that *when determining the Thevenin resistance all independent voltage sources are treated as short circuits, and all independent current sources are treated as open circuits.*

Secondly, if we are looking at constant inputs, then we use the fact that *a capacitor is an open circuit to dc and an inductor is a short circuit to dc. In addition, for constant inputs in steady state all of the time derivatives are zero (in steady state nothing changes in time).*

Example 2.2.1. Consider the circuit shown in Figure 2.1 (Example 2.1.1). The Thevenin resistance seen from the capacitor is equal to R , so the time constant is $\tau = RC$. For a dc input, the capacitor looks like an open circuit, so in steady state the voltage across the capacitor is equal to v_s , the input voltage, so the static gain is $K = 1$. These results match our previous results.

Example 2.2.2. Consider the circuit shown in Figure 2.2 (Example 2.1.2). The Thevenin resistance seen from the capacitor is $R_{th} = R_a \parallel R_b = \frac{R_a R_b}{R_a + R_b}$, so the time constant is $\tau = R_{th} C = \frac{R_a R_b C}{R_a + R_b}$. For a dc input, the capacitor looks like an open circuit, so in steady state the voltage across the capacitor is given by the voltage divider relationship $v_c = \frac{R_b}{R_a + R_b} v_s$, so the static gain is $K = \frac{R_b}{R_a + R_b}$. These results match our previous results.

Example 2.2.3. Consider the circuit shown in Figure 2.3 (Example 2.1.3). The Thevenin resistance seen by the capacitor is a little more difficult to determine, and to do it correctly is beyond the scope of this course. For a dc input, the capacitor looks like an open circuit, so summing the currents into the negative terminal of the op amp we have $\frac{v_c}{R_b} + \frac{v_s}{R_a} = 0$, or in steady state $v_c = -\frac{R_b}{R_a} v_s$. Hence the static gain is $K = -\frac{R_b}{R_a}$.

Example 2.2.4. Consider the circuit shown in Figure 2.4 (Example 2.1.4). The Thevenin resistance seen by the inductor is $R_{th} = R$. For a dc input, the inductor looks like a short circuit. Hence the steady state current flowing in the circuit for a dc input is $i = \frac{1}{R} v_s$, so the static gain is $K = \frac{1}{R}$.

Example 2.2.5. Consider the circuit shown in Figure 2.5 (Example 2.1.5). The Thevenin resistance seen by the capacitor is $R_{th} = R_b$ so the time constant is $\tau = R_b C$. For a dc input the capacitor looks like an open circuit, so in steady state $v_c = R_b i$, so the static gain is $K = R_b$.

2.3 Solving First Order Differential Equations

In this section we will go over two methods for solving first order differential equations. We will initially solve the equations by breaking the solution into the *natural response* (the response with no input) and then the *forced* response.
Copyright © 2009 Robert D. Throne

response (the response when the input is turned on). We will apply this method to problems where the input is a constant value, or is switched between constant values. This method will also work with any input, and we will examine the results for a sinusoidal input later. In the last section we will go over a different method of solution using *integrating factors*, which will work for any type of input, and is an important method in helping us characterize how a system will respond to any type of input.

2.3.1 Solution using Natural and Forced Responses

Consider a system described by the first order differential equation

$$\tau \frac{dy(t)}{dt} + y(t) = Kx(t)$$

In this equation, τ is the time constant and K is the *static gain*. We will solve this equation in two parts. We will first determine the *natural response*, $y_n(t)$. The natural response is the response due only to initial conditions when no inputs are present. Then we will determine the *forced response*, $y_f(t)$. The forced response is the response due to the input only, assuming all initial conditions are zero. The total response is then the sum of the natural and forced responses, $y(t) = y_n(t) + y_f(t)$.

Natural Response: To determine the natural response we assume there is no input in the system, so we have the equation

$$\tau \frac{dy_n(t)}{dt} + y_n(t) = 0$$

Let's assume a solution of the form $y_n(t) = c e^{rt}$, where c and r are parameters to be determined. Substituting this assumption into the differential equation we get

$$\tau r c e^{rt} + c e^{rt} = c e^{rt} [\tau r + 1] = 0$$

If $c = 0$ then we are done, and the natural response will be $y_n(t) = 0$. This solution certainly satisfies the differential equation. However, if $c \neq 0$, and since e^{rt} can never be zero, we must have $\tau r + 1 = 0$, or $r = -\frac{1}{\tau}$. In this case the natural response will be

$$y_n(t) = c e^{-t/\tau}.$$

Forced Response: To determine the forced response we must know the system input, $x(t)$. We will initially assume an input that is zero before $t = 0$ and then has constant amplitude A for $t \geq 0$,

$$x(t) = \begin{cases} 0 & t < 0 \\ A & t \geq 0 \end{cases}$$

Then for $t \geq 0$ we have the equation

$$\tau \frac{dy_f(t)}{dt} + y_f(t) = KA$$

Since this is a linear ordinary differential equation we only need to find one solution. One obvious solution to this equation is the solution in steady state, when $\frac{dy_f(t)}{dt} = 0$. In steady state we have

$$y_f(t) = KA$$

Note that for a constant input, the steady state output is the product of the static gain and the amplitude of the input.

Total Solution: The total solution to the problem is the sum of these two solutions

$$y(t) = y_n(t) + y_f(t) = ce^{-t/\tau} + KA$$

Now assume the initial time is $t = 0$ and the system is initially at rest, i.e. there is no energy stored in the system so $y(0) = 0$. Substituting this into our equation we have $y(0) = 0 = c + KA$, or $c = -KA$, and our total solution is

$$y(t) = KA(1 - e^{-t/\tau})$$

For simplicity, let's write our steady state value explicitly, so $y(\infty) = KA$ and we have the solution

$$y(t) = y(\infty)(1 - e^{-t/\tau})$$

Finally, let's determine a more general form of the solution for $y(0) \neq 0$. Then we have

$$y(0) = c + KA = c + y(\infty)$$

or

$$c = y(0) - y(\infty)$$

so the total solution is

$$y(t) = [y(0) - y(\infty)]e^{-t/\tau} + y(\infty)$$

Significance of the Time Constant

In much of what we do, we will be concerned with the time constants of a system in one way or another. Let's look at the response of our first order system assuming the system is initially at rest ($y(0) = 0$) and the final value is one ($y(\infty) = 1$). Let's look at the response of our system as the time t takes on the values of integer number of time constants:

Time (t)	t / τ	$y(t) = 1 - e^{-t/\tau}$
0	0	0
τ	1	0.632
2τ	2	0.865
3τ	3	0.950
4τ	4	0.982
5τ	5	0.993

Figure 2.6 show this result graphically, The way this information is usually interpreted is that a system is within 5% of its final value in 3 time constants, within 2% of its final value in 4 time constants, and within 1% of its final value in 5 time constants. Hence the use of time constants gives us a quick way to describe one aspect of the behavior of a system. As we will see, as the systems become more complex, the use of time constants indicates which part of the solution is the most important and how the system responds to periodic inputs (sines and cosines).

Example 2.3.1. Consider the circuit in Figure 2.2 (Example 2.1.2). Let's first assume $R_a = R_b = 2k\Omega$ and $C = 1\mu F$. Then $R_{th} = 1k\Omega$, $\tau = 1ms$, and $K = 0.5$. Next we will assume the initial voltage on the capacitor is zero ($v_c(t_0) = v_c(0) = 0$) and the input is as follows:

$$v_s(t) = \begin{cases} 0 & t < 0 \\ 2 & 0 \leq t \leq 8 \\ -2 & 8 < t \leq 16 \\ 1 & t > 16 \end{cases}$$

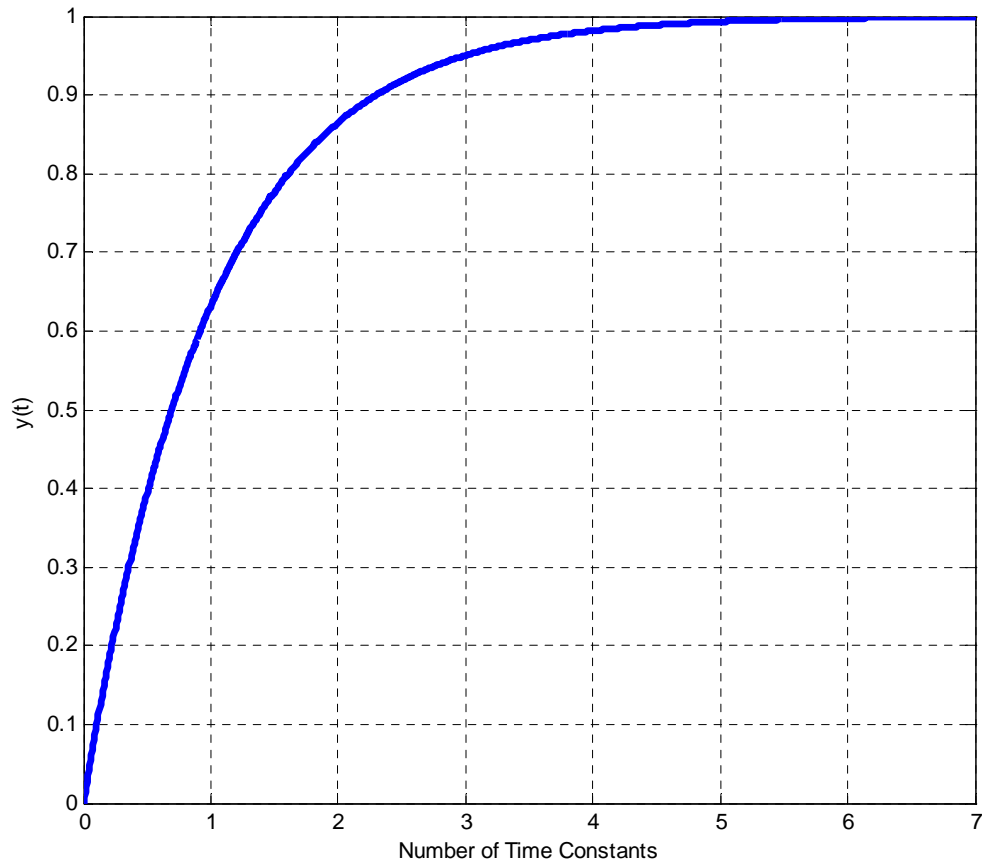

Figure 2.6. Graph of $y(t) = 1 - e^{-t/\tau}$ for $t = 0\tau$ up to $t = 7\tau$. $y(t)$ is within 5% of its final value in 3 time constant, within 2% of its final value in 4 time constants, and within 1% of its final value in 5 time constants.

Here the input is in volts and the time is measured in milliseconds. We now want to determine the output. We will do this by looking at the initial and final values for each time interval, where the time intervals are determined by the times during which the input voltage is constant. The differential equation is

$$\tau \frac{dv_c(t)}{dt} + v_c(t) = K v_s(t)$$

Clearly $y(t) = v_c(t)$ and $x(t) = v_s(t)$. The solution in each interval will be of the form

$$y(t) = [y(0) - y(\infty)]e^{-t/\tau} + y(\infty)$$

At this point we just need to be able to determine what $y(0)$ and $y(\infty)$ mean for each interval.

First interval ($0 \leq t < 8$ ms) : We have the initial value in this interval $y(0) = v_c(0) = 0$ volts. To determine the final value, we use the static gain and the amplitude of the input for this interval.

$$v_c(\infty) = y(\infty) = K \cdot 2 = \frac{1}{2} \cdot 2 = 1$$

Hence for this interval, we have the solution

$$v_c(t) = y(t) = -e^{-t/\tau} + 1 = 1 - e^{-t/0.001}$$

Before we go on to the next interval we need to figure out the value of $y(t)$ at the end of this interval, this value will be the initial point during the next interval. At the end of the interval we will have

$$y(0.008) = 1 - e^{-0.008/0.001} = 1 - e^{-8} = 0.99966 \approx 1.0$$

Second interval ($8 < t \leq 16$ ms) : The initial value for this interval will be the end point of the previous interval, so $y(0) = 1$. To determine the final value we again use the static gain

$$y(\infty) = K \cdot (-2) = \frac{1}{2} \cdot (-2) = -1$$

We now have almost everything we need, however, our solution assumed a time of zero was measured at the beginning of the interval. Hence to use our previous solution we need to subtract the time at the beginning of the interval from our actual time in our form of the solution, so our time will be measured from the beginning of the interval. Our solution for this interval is then

$$y(t) = [1 - (-1)]e^{-(t-0.008)/\tau} + (-1) = 2e^{-(t-0.008)/0.001} - 1$$

At the end of this interval we will have

$$y(0.016) = 2e^{-(0.016-0.008)/0.001} - 1 = 2e^{-8} - 1 = -0.99933 \approx -1.0$$

Third interval ($t > 16$ ms) : The initial value for this interval will be the end point of the previous interval, so $y(0) = -1$. To determine the final value we have

$$y(\infty) = K \cdot 1 = K = \frac{1}{2}$$

Again we must scale our solution so time is measured from the beginning of the interval, so we have

$$y(t) = [-1 - 0.5]e^{-(t-0.016)/\tau} + 0.5 = -1.5e^{-(t-0.016)/0.001} + 0.5$$

Total solution: To get the total solution, we list the solutions during each time interval:

$$v_c(t) = y(t) = \begin{cases} 0 & t < 0 \\ 1 - e^{-t/0.001} & 0 \leq t < 8 \text{ ms} \\ 2e^{-(t-0.008)/0.001} - 1 & 8 \leq t < 16 \text{ ms} \\ -1.5e^{-(t-0.016)/0.001} + 0.5 & t \geq 16 \text{ ms} \end{cases}$$

To get the current through the capacitor, we use the relationship $i_c(t) = C \frac{dv_c(t)}{dt}$ for each time interval above.

Doing this we get

$$i_c(t) = C \frac{dv_c(t)}{dt} = \begin{cases} 0 & t < 0 \\ 0.001e^{-t/0.001} & 0 \leq t < 8 \text{ ms} \\ 0.002e^{-(t-0.008)/0.001} & 8 \leq t < 16 \text{ ms} \\ -0.015e^{-(t-0.016)/0.001} & t \geq 16 \text{ ms} \end{cases}$$

Here $i_c(t)$ is measured in amps.

Figure 2.7 shows the input voltage, the voltage across the capacitor, and the current through the capacitor as a function of time. Note that the voltage across the capacitor is continuous, as it must be. However for this input, which is discontinuous, the current through the capacitor is discontinuous. Let's also look at the answer to see if we can check our results and if the answer makes sense. When the source voltage is initially turned on, the voltage across the capacitor is zero and all of the voltage generated by the source is equal to the voltage across resistor R_a . If there were any voltage drop across R_b at the initial time, there would also be a voltage drop across the capacitor since they are in parallel. In steady state, the capacitor looks like an open circuit, so there is no current flowing through the capacitor and the maximum possible voltage at this time is half the voltage of the source, which agrees with our results. In this example the input was held constant for an equivalent of eight time constants, so the voltage across the capacitor had essentially reached steady state.

Finally it is useful to point out that if the voltage across the capacitor is described by the relationship

$$v_c(t) = [v_c(0) - v_c(\infty)]e^{-t/\tau} + v_c(\infty)$$

Then the current through the capacitor is given by

$$i_c(t) = C \frac{dv_c(t)}{dt} = -\frac{C}{\tau} [v_c(0) - v_c(\infty)]e^{-t/\tau}$$

What this means is that if the voltage across a capacitor is growing exponentially, then the current through the capacitor is decreasing exponentially. Similarly, if the voltage across a capacitor is decreasing exponentially, the current through the capacitor will be growing exponentially. This is also behavior our results show. Similar results also hold for inductors.

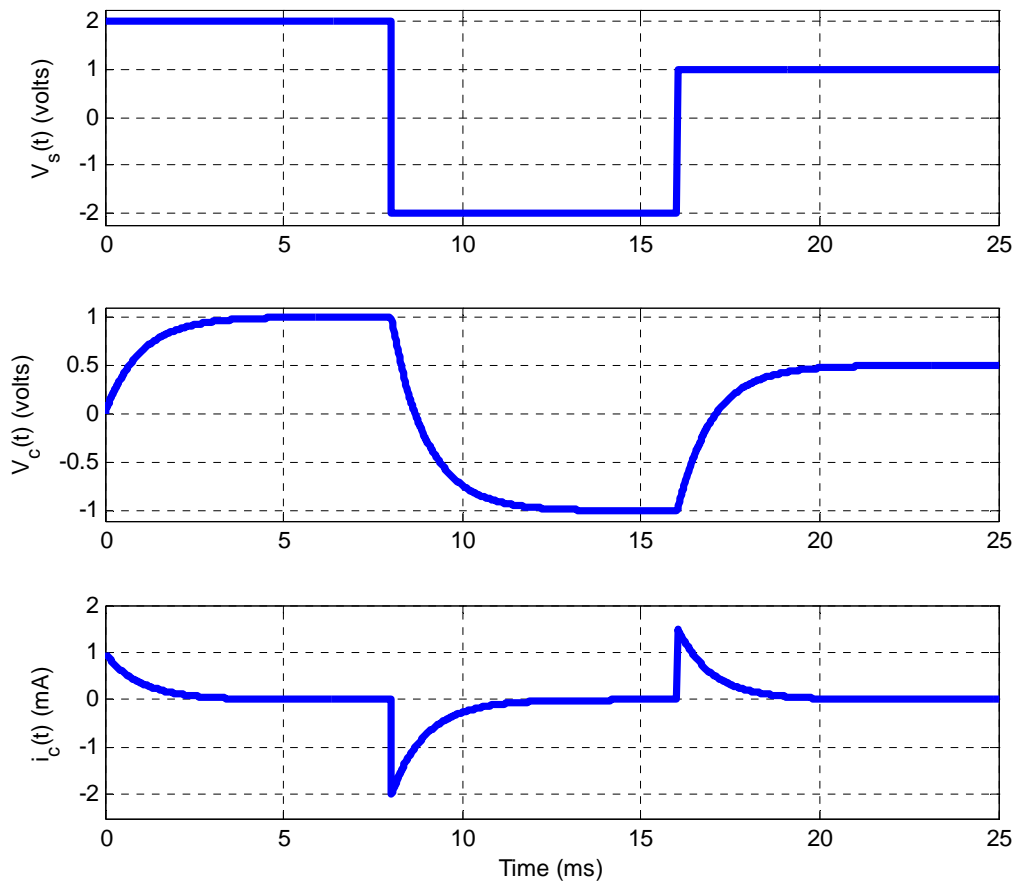

Figure 2.7. Results for Example 2.3.1.

Example 2.3.2. Consider the circuit in Figure 2.4 (Example 2.1.4). Let's first assume $R = R_{th} = 100 \Omega$ and $L = 10 \text{ mH}$. Then $\tau = \frac{L}{R} = \frac{0.01}{100} = 0.0001 = 100 \mu\text{s}$ and $K = 0.01$. Next we will assume the initial current through the inductor is $i(0) = 10 \text{ mA}$ and the input is as follows:

$$v_s(t) = \begin{cases} 0 & t < 0 \\ 2 & 0 \leq t < 0.1 \\ -3 & 0.1 \leq t < 0.25 \\ 4 & t \geq 0.25 \end{cases}$$

Here the input is in volts and the time is measured in milliseconds. We now want to determine the output. We will do this by looking at the initial and final values for each time interval, where the time intervals are determined by the times during which the input voltage is constant.

The differential equation for this system is again

$$\tau \frac{di(t)}{dt} + i(t) = K v_s(t)$$

Clearly $y(t) = i(t)$ and $x(t) = v_s(t)$. The solution in each interval will be of the form

$$y(t) = [y(0) - y(\infty)]e^{-t/\tau} + y(\infty)$$

At this point we just need to be able to determine what $y(0)$ and $y(\infty)$ mean for each interval.

First interval ($0 \leq t < 0.1 \text{ ms}$) : We have the initial value $y(0) = i(0) = 0.01$ amps in this interval. To determine the final value, we use the static gain and the amplitude of the input for this interval

$$i(\infty) = y(\infty) = K \cdot 2 = \frac{1}{100} \cdot 2 = 0.02$$

Hence for this interval, we have the solution

$$y(t) = [y(0) - y(\infty)]e^{-t/\tau} + y(\infty) = [0.01 - 0.02]e^{-t/\tau} + 0.02 = -0.01e^{-t/0.0001} + 0.02$$

Before we go on to the next interval we need to figure out the value of $y(t)$ at the end of this interval, this value will be the initial point during the next interval. At the end of the interval we will have

$$y(0.0001) = -0.01e^{-0.0001/0.0001} + 0.02 = -0.01e^{-1} + 0.02 = 0.01632$$

Third interval ($0.1 \leq t < 0.25 \text{ ms}$) : The initial value for this interval will be the end point of the previous interval, so $y(0) = 0.01632$. To determine the final value we again use the static gain

$$y(\infty) = K \cdot (-3) = 0.01 \cdot (-3) = -0.03$$

We again need to subtract the time at the beginning of the interval from our actual time in our form of the solution, so our time will be measured from the beginning of the interval. Our solution for this interval is then

$$y(t) = [0.01632 - (-0.03)]e^{-(t-0.0001)/\tau} + (-0.03) = 0.04632e^{-(t-0.0001)/0.0001} - 0.03$$

At the end of this interval we will have

$$y(0.00025) = 0.04632e^{-(0.00025-0.0001)/0.0001} - 0.03 = 0.04632e^{-1.5} - 0.03 = -0.01966$$

Fourth interval ($t \geq 0.25 \text{ ms}$) : The initial value for this interval will be the end point of the previous interval, so $y(0) = -0.01966$. To determine the final value we have

$$y(\infty) = K \cdot 4 = 0.04$$

Again we must scale our solution so time is measured from the beginning of the interval, so we have

$$y(t) = [-0.01966 - 0.04]e^{-(t-0.0025)/\tau} + 0.04 = -0.05966e^{-(t-0.0025)/0.0001} + 0.04$$

Total solution: To get the total solution, we list the solutions during each time interval:

$$i_L(t) = y(t) = \begin{cases} 0 & t < 0 \\ -0.01e^{-t/0.0001} + 0.02 & 0 \leq t < 0.1 \text{ ms} \\ 0.04632e^{-(t-0.0001)/0.0001} - 0.03 & 0.1 \leq t < 0.25 \text{ ms} \\ -0.05966e^{-(t-0.00025)/0.0001} + 0.04 & t \geq 0.25 \text{ ms} \end{cases}$$

To get the voltage across the inductor we use the relationship $v_L(t) = L \frac{di_L(t)}{dt}$ and compute the voltage for each time interval. Doing this we get

$$v_L(t) = L \frac{di_L(t)}{dt} = \begin{cases} 0 & t < 0 \\ e^{-t/0.0001} & 0 \leq t < 0.1 \text{ ms} \\ -4.632e^{-(t-0.0001)/0.0001} & 0.1 \leq t < 0.25 \text{ ms} \\ 5.966e^{-(t-0.00025)/0.0001} & t \geq 0.25 \text{ ms} \end{cases}$$

Figure 2.8 shows the input voltage, the current through the inductor, and the voltage across the inductor as a function of time. Note that the current through the inductor is continuous, as it must be, while in this case the voltage across the inductor is not continuous. Again let's look at our solution to see if it makes sense. First of all, the voltage/current relationships for the inductor are consistent with what we expect. The initial current in the inductor is 10 mA, as we require, and the initial voltage from the source is 2 volts. Applying Kirchoff's laws around the loop, we expect the initial voltage drop across the inductor to be given by $v_s(0) - i(0)R = 2 - (0.01)(100) = 1$ volts, which is what we have. In steady state the inductor looks like a short circuit, so there should be no voltage drop across the inductor once the system reaches steady state, which again matches our results. Note that the system only reaches steady state near 0.7 or 0.8 ms. In addition, in steady state the voltage drop across the resistor must match the voltage supplied by the source, or $v_s(\infty) - i(\infty)R = 4 - (0.04)(100) = 0$ volts, which again matches our results. Let's look at the results at one other convenient point in time, say $t = 0.2 \text{ ms}$. Using the equations we derived above (and the known input) we have

$$\begin{aligned} v_s(0.0002) &= -3 \text{ volts} \\ i_L(0.0002) &= -12.96 \text{ mA} \\ v_L(0.0002) &= -1.70 \text{ volts} \end{aligned}$$

Applying Kirchoff's laws around the loop we have

$$v_s(0.0002) - i_s(0.0002)R - v_L(0.0002) = -3 - (-0.01296)(100) - (-1.70) \approx 0.0$$

We can obviously check as many points in time as we want in this way. This type of checking does not guarantee our answer is correct, but it does help find obvious errors.

2.3.2 Solution Using Integrating Factors

An alternative method of solution of first order differential equations is by the use of *integrating factors*. This method of solution is important to understand because as we start to analyze different types of *systems*, we need to be able to understand how we would solve for the output when we don't actually know what the input is. This helps us characterize systems independent of the actual (specific) input.

The use of integrating factors for solving first order differential equations is based on the fact that when we differentiate an exponential, we get the same exponential back multiplied by some other term. For example, if $x(t) = e^{\phi(t)}$, then

$$\frac{d}{dt}x(t) = \frac{d}{dt}e^{\phi(t)} = e^{\phi(t)} \frac{d\phi(t)}{dt} = x(t) \frac{d\phi(t)}{dt}$$

In what follows, the method looks fairly lengthy, but with practice most of the steps can be done in your head. Let's apply this idea to our equation

$$\tau \frac{dy(t)}{dt} + y(t) = Kx(t)$$

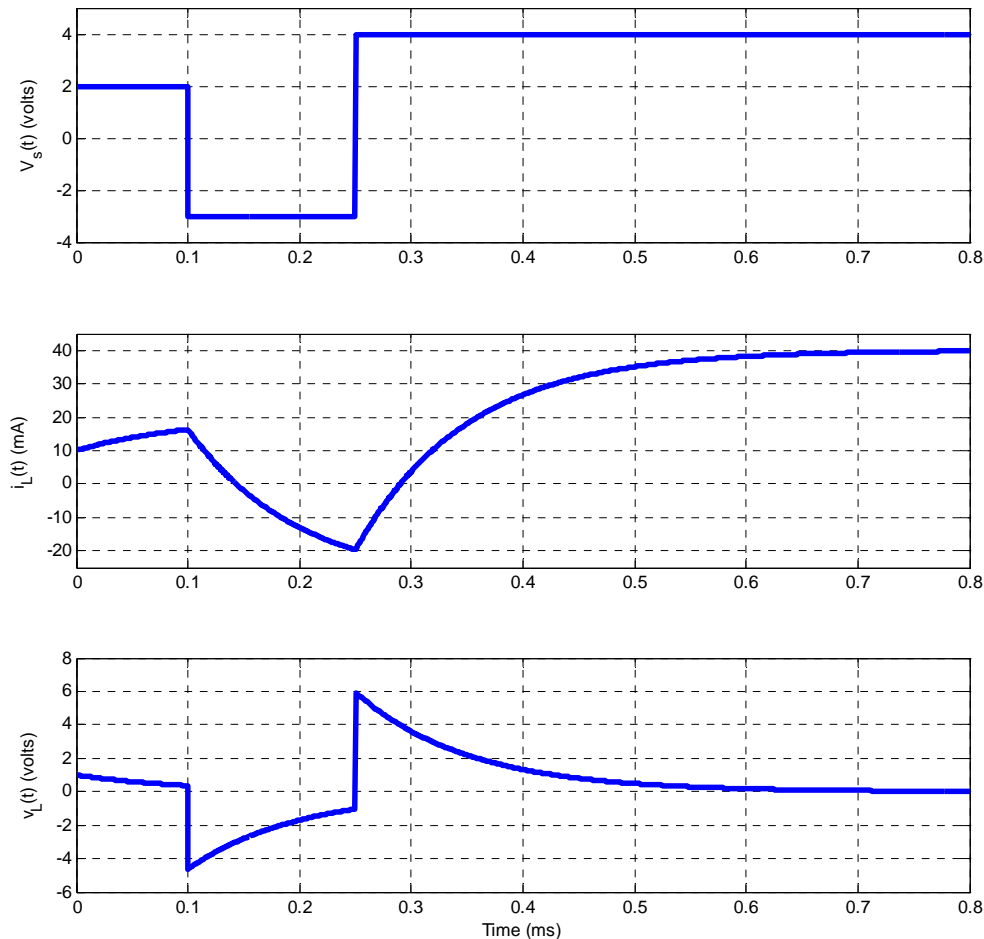

Figure 2.8. Results for Example 2.3.2.

This method will work better if we rearrange our equation a bit to the form

$$\frac{dy(t)}{dt} + \frac{1}{\tau} y(t) = \frac{K}{\tau} x(t)$$

Next, we look at differentiating the product $y(t)e^{\phi(t)}$, where $\phi(t)$ will be determined by the differential equation we are trying to solve. This leads to the equation

$$\frac{d}{dt} \left[y(t)e^{\phi(t)} \right] = \frac{dy(t)}{dt} e^{\phi(t)} + y(t) \frac{d\phi(t)}{dt} e^{\phi(t)} = e^{\phi(t)} \left[\frac{dy(t)}{dt} + \frac{d\phi(t)}{dt} y(t) \right]$$

Next, we equate the term in brackets to the left hand side of our original differential equation,

$$\frac{dy(t)}{dt} + \frac{d\phi(t)}{dt} y(t) = \frac{dy(t)}{dt} + \frac{1}{\tau} y(t)$$

Clearly this means that

$$\frac{d\phi(t)}{dt} = \frac{1}{\tau}$$

Solving this simple equation we get

$$\phi(t) = \frac{t}{\tau}$$

Now we put this back into our equation above to get

$$\frac{d}{dt} \left[y(t)e^{t/\tau} \right] = \frac{dy(t)}{dt} e^{t/\tau} + y(t) \frac{1}{\tau} e^{t/\tau} = e^{t/\tau} \left[\frac{dy(t)}{dt} + \frac{1}{\tau} y(t) \right]$$

The term on the far right is the same as the left hand side of our differential equation multiplied by $e^{t/\tau}$, so this must equal the right hand side of our differential equation multiplied by the same thing,

$$\frac{d}{dt} \left[y(t)e^{t/\tau} \right] = e^{t/\tau} \left[\frac{dy(t)}{dt} + \frac{1}{\tau} y(t) \right] = e^{t/\tau} \left[\frac{K}{\tau} x(t) \right]$$

Next we eliminate the middle term to get the exact differential we want

$$\frac{d}{dt} \left[y(t)e^{t/\tau} \right] = e^{t/\tau} \left[\frac{K}{\tau} x(t) \right]$$

Finally we integrate from and initial time t_0 with initial value $y(t_0)$ to final time t with value $y(t)$,

$$\int_{t_0}^t \frac{d}{d\lambda} \left[y(\lambda)e^{\lambda/\tau} \right] d\lambda = \int_{t_0}^t e^{\lambda/\tau} \frac{K}{\tau} x(\lambda) d\lambda$$

The left hand side can be integrated as

$$\int_{t_0}^t \frac{d}{d\lambda} \left[y(\lambda)e^{\lambda/\tau} \right] d\lambda = y(t)e^{t/\tau} - y(t_0)e^{t_0/\tau} = \int_{t_0}^t e^{\lambda/\tau} \frac{K}{\tau} x(\lambda) d\lambda$$

or

$$y(t) = y(t_0)e^{-(t-t_0)/\tau} + \int_{t_0}^t e^{-(t-\lambda)/\tau} \frac{K}{\tau} x(\lambda) d\lambda$$

This is the general solution, for any input $x(t)$.

Example 2.3.1. Let's now look at the same input as before, $x(t) = A$ for $t \geq 0$ with initial condition $t_0 = 0$ and $y(t_0) = y(0)$. The solution to the differential equation becomes

$$y(t) = y(0)e^{-t/\tau} + \int_0^t e^{-(t-\lambda)/\tau} \frac{K}{\tau} Ad \lambda$$

$$y(t) = y(0)e^{-t/\tau} + e^{-t/\tau} \int_0^t e^{\lambda/\tau} \frac{K}{\tau} Ad \lambda$$

$$y(t) = y(0)e^{-t/\tau} + e^{-t/\tau} KA \left[e^{\lambda/\tau} \right]_{\lambda=0}^{\lambda=t}$$

$$y(t) = y(0)e^{-t/\tau} + e^{-t/\tau} KA \left[e^{t/\tau} - 1 \right]$$

$$y(t) = y(0)e^{-t/\tau} + KA \left[1 - e^{-t/\tau} \right]$$

With the substitution $y(\infty) = KA$, we get

$$y(t) = y(0)e^{-t/\tau} + y(\infty) \left[1 - e^{-t/\tau} \right]$$

or

$$y(t) = \left[y(0) - y(\infty) \right] e^{-t/\tau} + y(\infty)$$

the same solution as before.

Example 2.3.2. Let's use integration factors to determine the solution to the differential equation

$$\frac{dy(t)}{dt} = ay(t) + bx(t)$$

The first thing we need to do is put all of the y terms on the left hand side,

$$\frac{dy(t)}{dt} - ay(t) = bx(t)$$

Then we need

$$\frac{d\phi(t)}{dt} = -a$$

or

$$\phi(t) = -at$$

Then we have

$$\frac{d}{dt} \left[y(t)e^{-at} \right] = e^{-at} bx(t)$$

Integrating both sides we get

$$\int_{t_0}^t \frac{d}{d\lambda} \left[e^{-a\lambda} y(\lambda) \right] d\lambda = e^{-at} y(t) - e^{-at_0} y(t_0) = \int_{t_0}^t e^{-a\lambda} bx(\lambda) d\lambda$$

or

$$y(t) = e^{a(t-t_0)} y(t_0) + e^{at} \int_{t_0}^t e^{-a\lambda} bx(\lambda) d\lambda$$

Example 2.3.3. Let's use integration factors to determine the solution to the differential equation

$$\frac{dy(t)}{dt} - ty(t) = 2x(t)$$

Then we need

$$\frac{d\phi(t)}{dt} = -t$$

or

$$\phi(t) = -\frac{t^2}{2}$$

Then we have

$$\frac{d}{dt} \left[y(t) e^{-\frac{t^2}{2}} \right] = e^{-\frac{t^2}{2}} 2x(t)$$

Integrating both sides we get

$$\int_{t_0}^t \frac{d}{d\lambda} \left[e^{-\frac{\lambda^2}{2}} y(\lambda) \right] d\lambda = e^{-\frac{t^2}{2}} y(t) - e^{-\frac{t_0^2}{2}} y(t_0) = \int_{t_0}^t e^{-\frac{\lambda^2}{2}} 2x(\lambda) d\lambda$$

or

$$y(t) = e^{\left(\frac{t^2}{2} - \frac{t_0^2}{2}\right)} y(t_0) + e^{\frac{t^2}{2}} \int_{t_0}^t e^{-\frac{\lambda^2}{2}} 2x(\lambda) d\lambda$$

Chapter 2 Problems

2.1) For each of the circuits below:

i) Determine the governing differential equation using Kirchhoff's Laws and write it in standard form. For part F the output is the voltage across resistor R_C .

ii) Determine the time constant and static gain from the differential equation you derive in (i)

iii) For all circuits except F, determine the Thevenin resistance from the ports of the capacitor or inductor and verify the time constants.

iv) For all circuits except F, determine the static gain by determining the DC voltage across the capacitor or the current through and inductor.

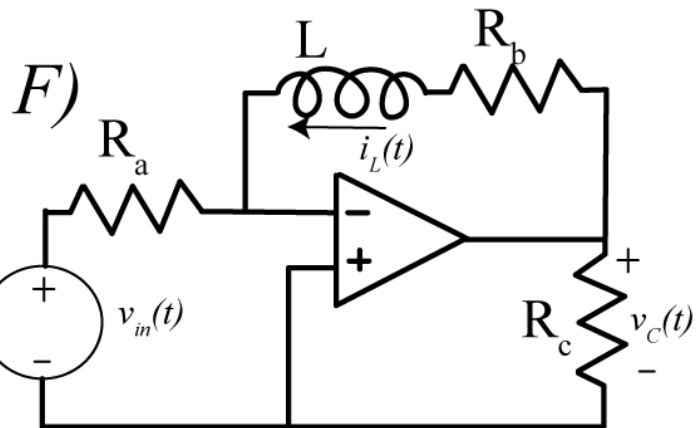
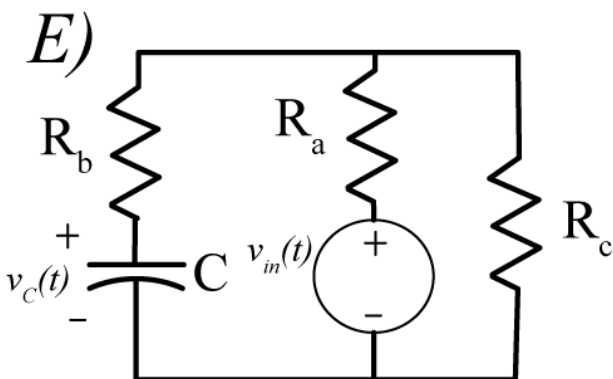
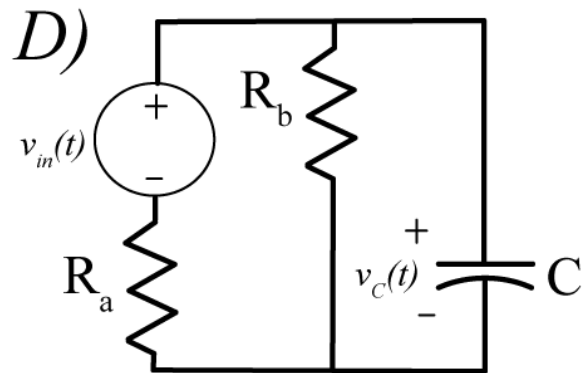
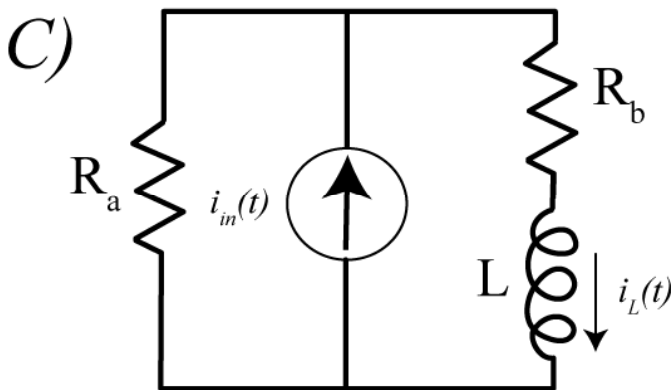
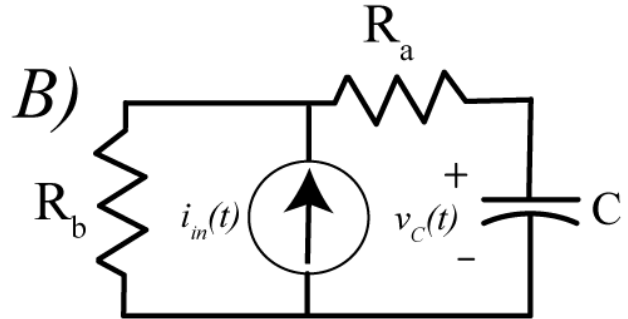
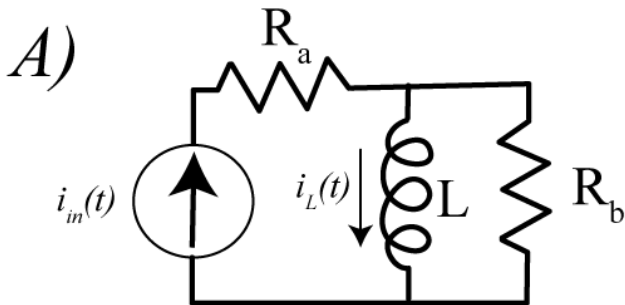

Answers:

$$\left(\frac{L}{R_b}\right)\frac{di_L(t)}{dt} + i_L(t) = i_{in}(t), \quad C(R_a + R_b)\frac{dv_C(t)}{dt} + v_C(t) = R_b i_{in}(t)$$

$$\left(\frac{L}{R_a + R_b}\right)\frac{di_L(t)}{dt} + i_L(t) = \left(\frac{R_a}{R_a + R_b}\right)i_{in}(t), \quad C\left(\frac{R_a R_b}{R_a + R_b}\right)\frac{dv_C(t)}{dt} + v_C(t) = \left(\frac{R_b}{R_a + R_b}\right)v_{in}(t)$$

$$C\left(\frac{R_a R_b + R_c R_b + R_a R_c}{R_a + R_c}\right)\frac{dv_C(t)}{dt} + v_C(t) = \left(\frac{R_c}{R_a + R_c}\right)v_{in}(t), \quad \left(\frac{L}{R_b}\right)\frac{dv_{in}(t)}{dt} + v_{in}(t) = -\left(\frac{R_a}{R_b}\right)v_C(t)$$

2.2) For a simple series RC circuit the response of the system when the input is a unit step is

$$y(t) = 1 - e^{-t/RC} = 1 - e^{-t/\tau}$$

The 10-90% rise time, t_r , as shown below. The rise time is simply the amount of time necessary for the output to rise from 10% to 90% of its final value. Show that for this system the rise time is given by $t_r = \tau \ln(9)$

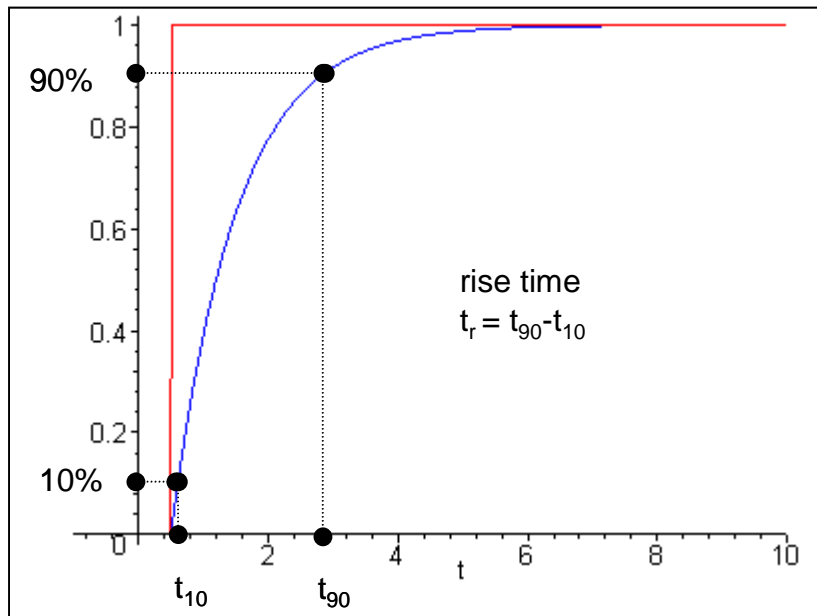

2.3) For each of the circuits below:

i) Determine the governing differential equation using Kirchoff's Laws and write it in standard form.

ii) Determine the time constant and static gain from the differential equation you derive in (i)

iii) For all circuits except F, determine the Thevenin resistance from the ports of the capacitor or inductor and verify the time constants.

iv) For all circuits except F, determine the static gain by determining the DC voltage across the capacitor or the current through and inductor.

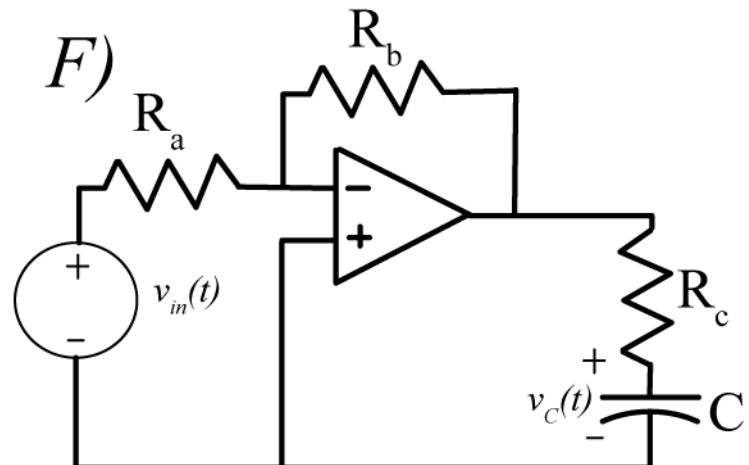
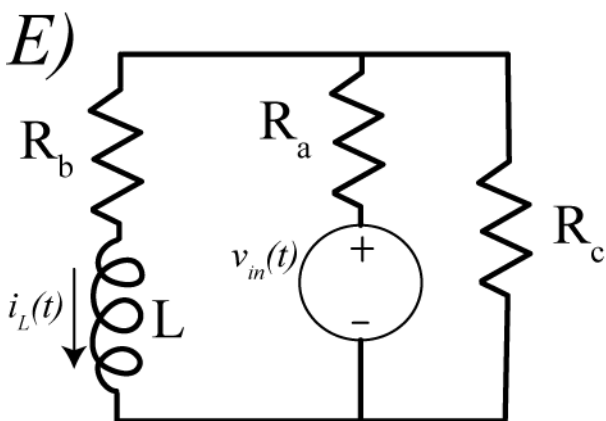
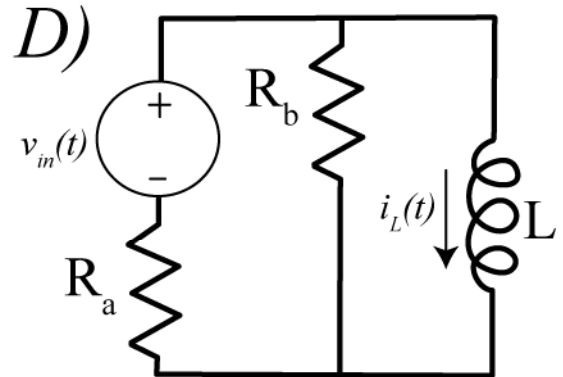
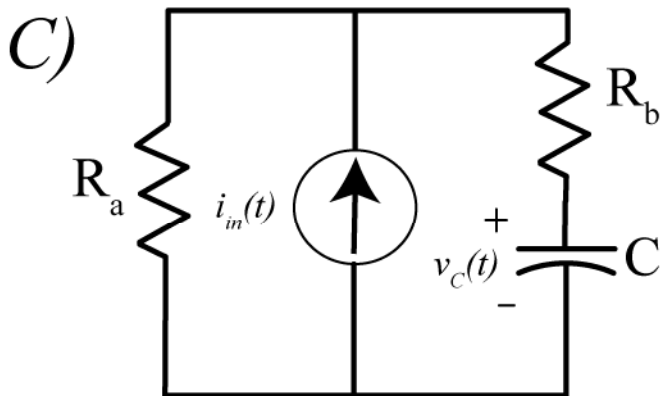
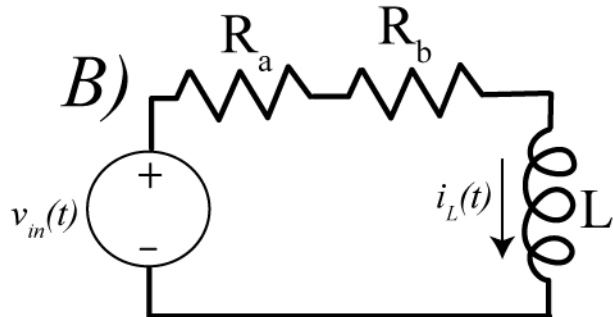
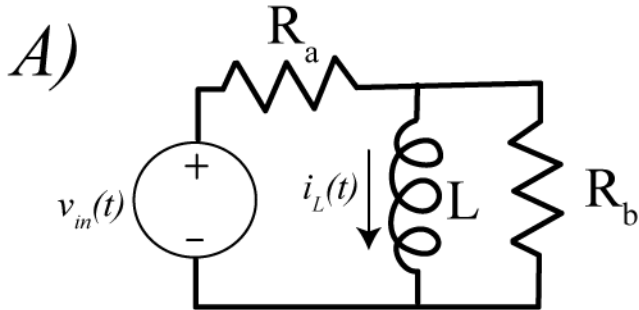

Answers:

$$\frac{(R_a + R_b)L}{R_a R_b} \frac{di_L(t)}{dt} + i_L(t) = \frac{1}{R_a} V_{in}(t), \quad \frac{L}{R_a + R_b} \frac{di_L(t)}{dt} + i_L(t) = \frac{1}{R_a + R_b} V_{in}(t)$$

$$(R_a + R_b)C \frac{dv_C(t)}{dt} + v_C(t) = R_a i_{in}(t), \quad \frac{(R_a + R_b)L}{R_a R_b} \frac{di_L(t)}{dt} + i_L(t) = \frac{1}{R_a} v_{in}(t)$$

$$\frac{(R_a + R_c)L}{R_a R_c + R_b R_c + R_a R_b} \frac{di_L(t)}{dt} + i_L(t) = \frac{R_c}{R_a R_c + R_b R_c + R_a R_b} v_{in}(t), \quad CR_c \frac{dv_C(t)}{dt} + v_C(t) = -\frac{R_b}{R_a} v_{in}(t)$$

2.4) Consider a first order system described by the differential equation $\tau \dot{y}(t) + y(t) = Kx(t)$.

- a) If the initial value is $y(0) = 0$ and the final value is $y(\infty) = 10$, what is $y(4\tau)$?
- b) If the initial value is $y(0) = -2$ and the final value is $y(\infty) = 8$, what is $y(4\tau)$?
- c) If the initial value is $y(0) = 1$ and the final value is $y(\infty) = -4$, what is $y(4\tau)$?

Answers: 9.82, 7.82, -3.90

2.5) An RC circuit has parameters $R_{th} = R_a \parallel R_b$, $\tau = R_{th}C$, $K = R_{th}$ and is described by the first order equation

$$\tau \frac{dv_C(t)}{dt} + v_C(t) = K i_{in}(t)$$

For this circuit $R_a = 100 \Omega$, $R_b = 200 \Omega$, and $C = 2 \text{ mf}$. The input current is

$$i_{in}(t) = \begin{cases} 0 & t \leq 0 \\ 1 \text{ mA} & 0 \leq t < 0.2 \text{ sec} \\ 2 \text{ mA} & 0.2 \leq t < 0.4 \text{ sec} \\ -3 \text{ mA} & t \geq 0.4 \text{ sec} \end{cases}$$

- a) Determine an analytical expression for the voltage across the capacitor in each of these regions
- b) Enter your analytical expression as an anonymous function in Matlab, and simulate the system using Simulink. Show that all three of your answers are identical. Turn in your Matlab (driver file) code and your neatly labeled plots. Be sure to set the initial value of the integrator to zero.

2.6) An RL circuit has parameters $R_{th} = R_a + R_b + R_c$, $\tau = L / R_{th}$, $K = (R_a + R_b) / R_{th}$ and is described by the first order equation

$$\tau \frac{di_L(t)}{dt} + i_L(t) = K i_{in}(t)$$

For this circuit, $R_a = R_b = R_c = 10 \Omega$ and $L = 8 \text{ mh}$. The input current is

$$i_{in}(t) = \begin{cases} 0 & t \leq 0 \\ 0.02 \text{ A} & 0 \leq t < 0.4 \text{ ms} \\ -0.03 \text{ A} & 0.4 \leq t < 1.0 \text{ ms} \\ 0.05 \text{ A} & t \geq 1.0 \text{ ms} \end{cases}$$

- a) Determine an analytical expression for the current through the inductor in each of these regions
- b) Enter your analytical expression as an anonymous function in Matlab, and simulate the system using Simulink. Show that all three of your answers are identical. Turn in your Matlab (driver file) code and your neatly labeled plots.

2.7) For each of the following first order differential equations, use an integrating factor to write $y(t)$ as a function of its initial value $y(t_0)$ and an integral of the input (plus some other functions)

$$\dot{y}(t) = ay(t) + bx(t) \quad \dot{y}(t) = aty(t) + bx(t)$$

$$\dot{y}(t) + \frac{1}{t}y(t) = x(t) \quad \dot{y}(t) + \frac{1}{t^2}y(t) = x(t-1)$$

Answers:

$$y(t) = e^{a(t-t_0)}y(t_0) + \int_{t_0}^t be^{a(t-\lambda)}x(\lambda)d\lambda \quad y(t) = e^{\frac{a}{2}(t^2-t_0^2)}y(t_0) + \int_{t_0}^t be^{\frac{a}{2}(t^2-\lambda^2)}x(\lambda)d\lambda$$

$$y(t) = \left(\frac{t_0}{t}\right)y(t_0) + \int_{t_0}^t \left(\frac{\lambda}{t}\right)x(\lambda)d\lambda \quad y(t) = e^{\left(\frac{1}{t}-\frac{1}{t_0}\right)}y(t_0) + \int_{t_0}^t e^{\left(\frac{1}{t}-\frac{1}{\lambda}\right)}x(\lambda-1)d\lambda$$