

ECE-205 Lab 8

Feedback Control Systems

Overview

In this lab you will build a simple feedback control system using both a proportional and proportional plus integral controller. The systems you will be controlling are simple first and second order systems. We will also be utilizing a prefilter to adjust the gain so the output follows the input. Be careful to build and test the circuit in pieces. Set your oscilloscope screen to have traces of width 4, using Display Options-> Trace Width 4. Also save your screen captures with a black background, they are much easier to read. Finally, for the battery pack, the red is positive, the green is negative, and the black is ground.

PART I : Proportional Control for a First Order System

Our proportional controller has five parts, shown in the different shaded regions in Figure 1. The equivalent block diagram is shown below the circuit, so you can match elements of the block diagram with the circuit subsystems. As with most of the circuits in this class, this design has not been optimized and is a bit inefficient, but should be fairly easy to build. All of the resistors are either 1 kΩ resistors, or are variable resistors. The single capacitor is a 1 μf capacitor. (We will later use a 0.01 μf capacitor and a 33 mH inductor, just as we did in Lab 2.) We will be utilizing TL072 chips (google the spec sheet if you need to), which include two op amps on each chip. We will build and debug this circuit in stages, so do not start building yet!

The first shaded part is the prefilter, which changes the gain of the system so the steady state value of the output matches the steady state value of the input. The next stage is the differential amplifier, or the feedback element. The third stage is the proportional gain controller (another gain stage). The fourth stage is the plant or system we want to control. The final stage is a simple isolation amplifier to avoid loading effects. Note that the output is the voltage across the capacitor.

It is a good idea to disconnect the power from your circuit while you are building it. Note that it may take some time for the screen to update when you change the variable resistor values. Be patient, and you will be rewarded. If you are impatient you will have to go back and redo parts of the lab!

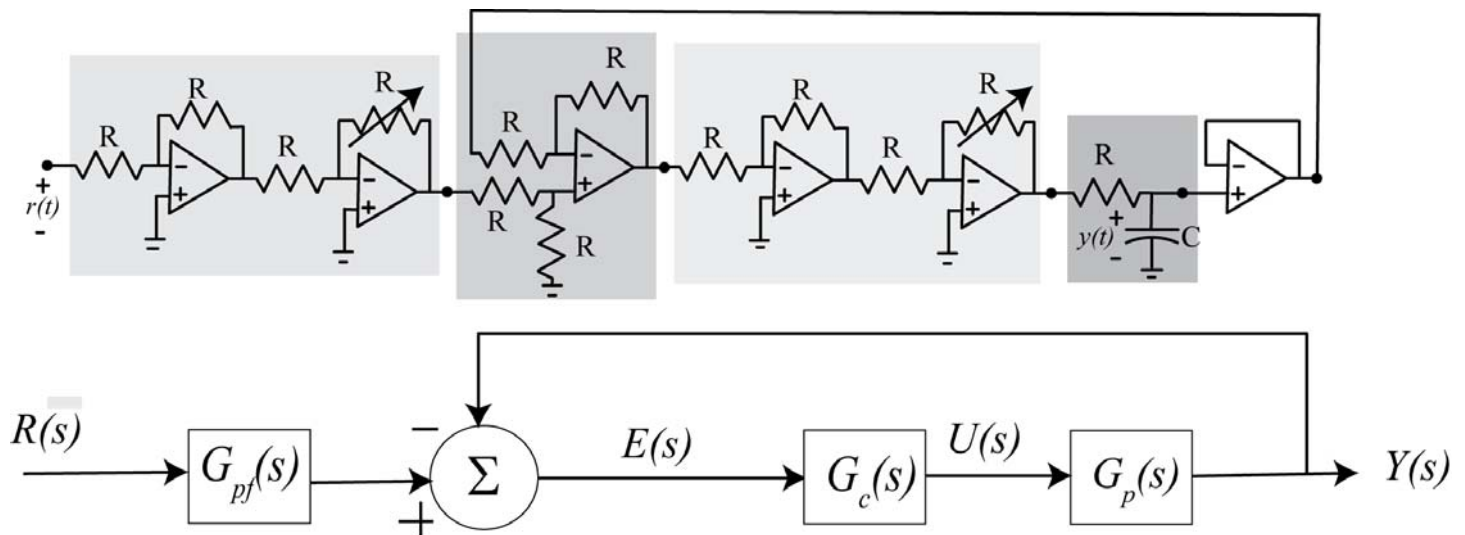

Figure 1. Proportional controller for the first order circuit.

1) Build the prefilter, shown in Figure 2. We have included a load resistor for measuring the output. The input to this circuit should be the signal generator, and the output should be the voltage across the load resistor. Set the input to a 50 Hz square wave with a peak to peak value of 2.0 volts and zero offset. Start the oscilloscope and set the input on channel 1 to **A1-Diff** and use this to measure the input signal (never trust a signal generator) and the input on channel 2 to **A2-Diff**, and use this to measure the voltage drop across the load resistor. Set channel 1 to **500 m volt/div** and channel 2 to **2 volts/div** (initially). Set the **Time/Div** to 2.00 ms and the **Mode** to **Y-T**. The coupling should be set to **DC** for both channels. As the variable resistor is changed, you should be able to get an amplitude from 0 to approximately 4 volts (8 volts peak to peak) . Before you go on, set the variable resistor so the output is that same as the input, but *be sure the change the scale on channel 2 to 500 mV/division before you do this*, so the scale is the same for channel 1 and channel 2. Once this is working, disconnect the load resistor and function generator and disconnect the power to the circuit.

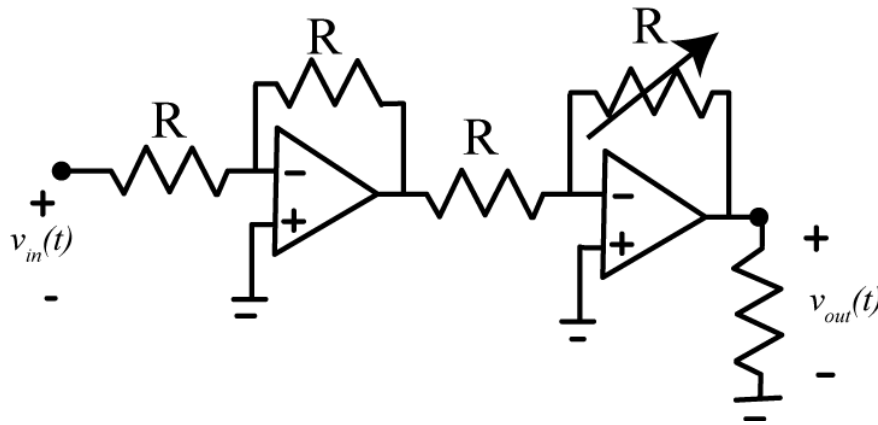

Figure 2. Prefilter (gain) circuit.

2) Build the differential amplifier, shown in Figure 3. Note that at this point we have connected the feedback input to ground. Again, we have included a load resistor to measure the output for debugging purposes. You should use a single chip for this (and waste an op amp) so your circuit will be easier to debug. Do not connect this to the prefilter circuit yet, but you should put this close to your prefilter so you will have room on your board for the rest of the circuit. Connect the signal generator to the input of this circuit and measure the output. They should be equal, if they are not you need to check your wiring.

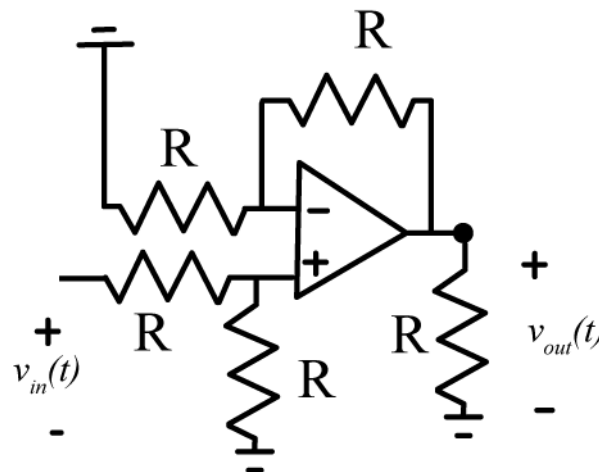

Figure 3. Differential amplifier circuit.

3) Now connect the first two parts of your circuit, the prefilter and the differential amplifier, as shown in Figure 4. The output of this combined circuit should match the input. If it is a little off, modify the variable resistor so they match (though they should be close). Do not go on if the input and output do not match.

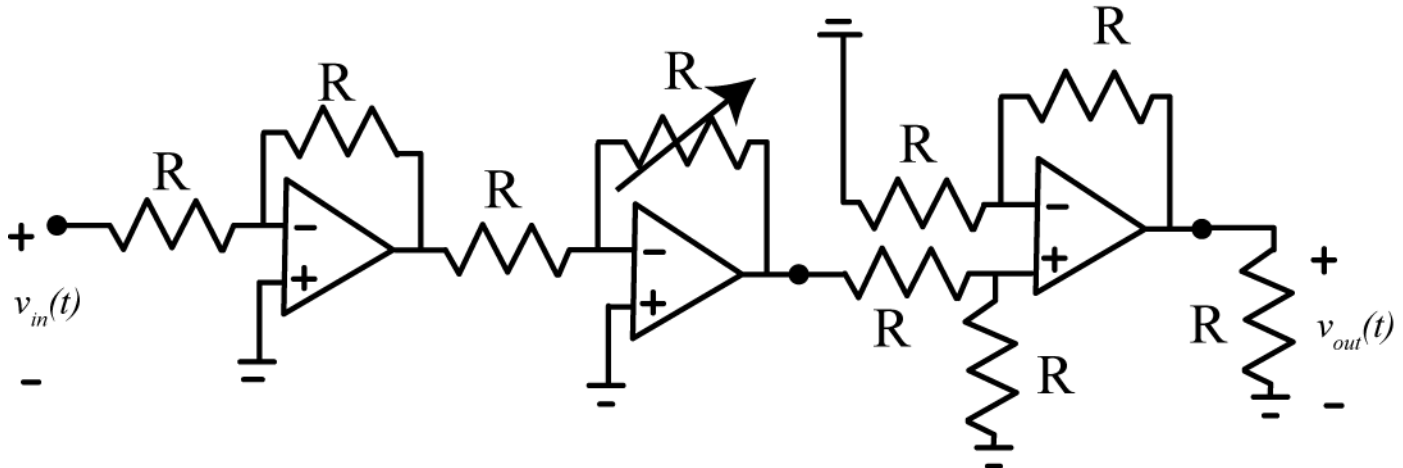

Figure 4. Prefilter and differential amplifier.

4) Build the controller (proportional amplifier). Follow the same steps as in the prefilter. Test this in the same way as you tested the prefilter. Before you go on, set the variable resistor so the output is the same as the input.

5) Connect the first three stages of your system, as shown in Figure 5. The output should match the input. If it does not, modify the variable resistor on the controller. Be sure to remove the load resistor before you go on.

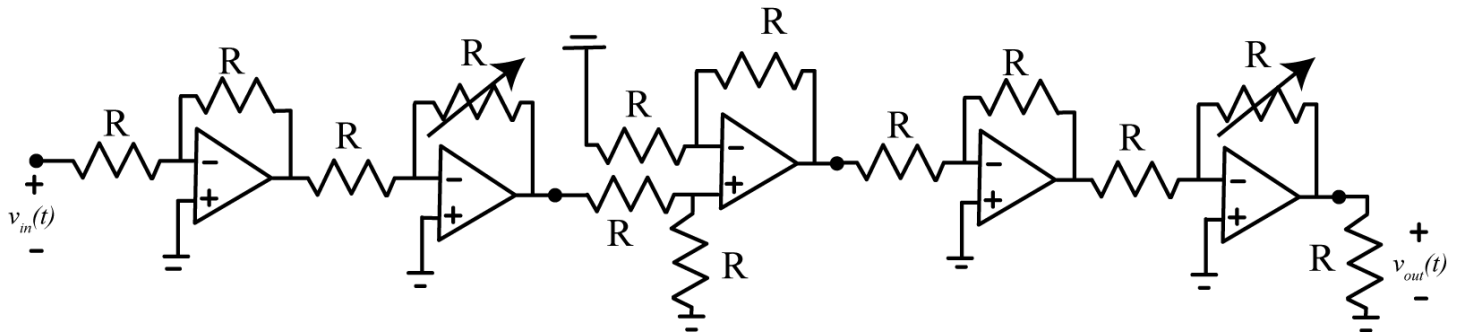

Figure 5. Prefilter, differential amplifier, and proportional controller.

6) Build the system, or plant, shown in Figure 6. In this figure we have included a load resistor to measure the output of the isolation amplifier. *Note that the positive terminal is not connected to ground in this circuit!* Measure the output as the voltage across the capacitor. This is the response the system for an open loop configuration. You should get a response something like that shown in Figure 7. Do not disconnect the load resistor yet.

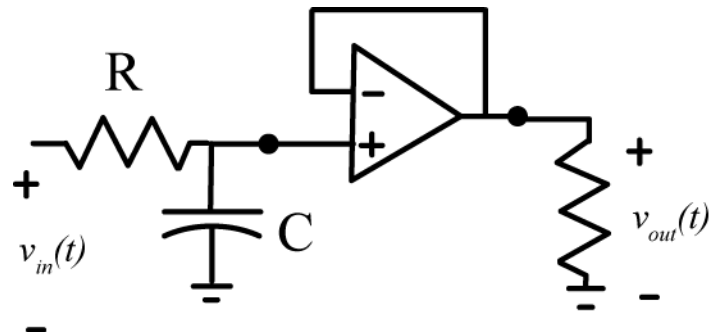

Figure 6. The system we are trying to control, or the plant. There is an isolating amplifier after the plant to avoid loading effects.

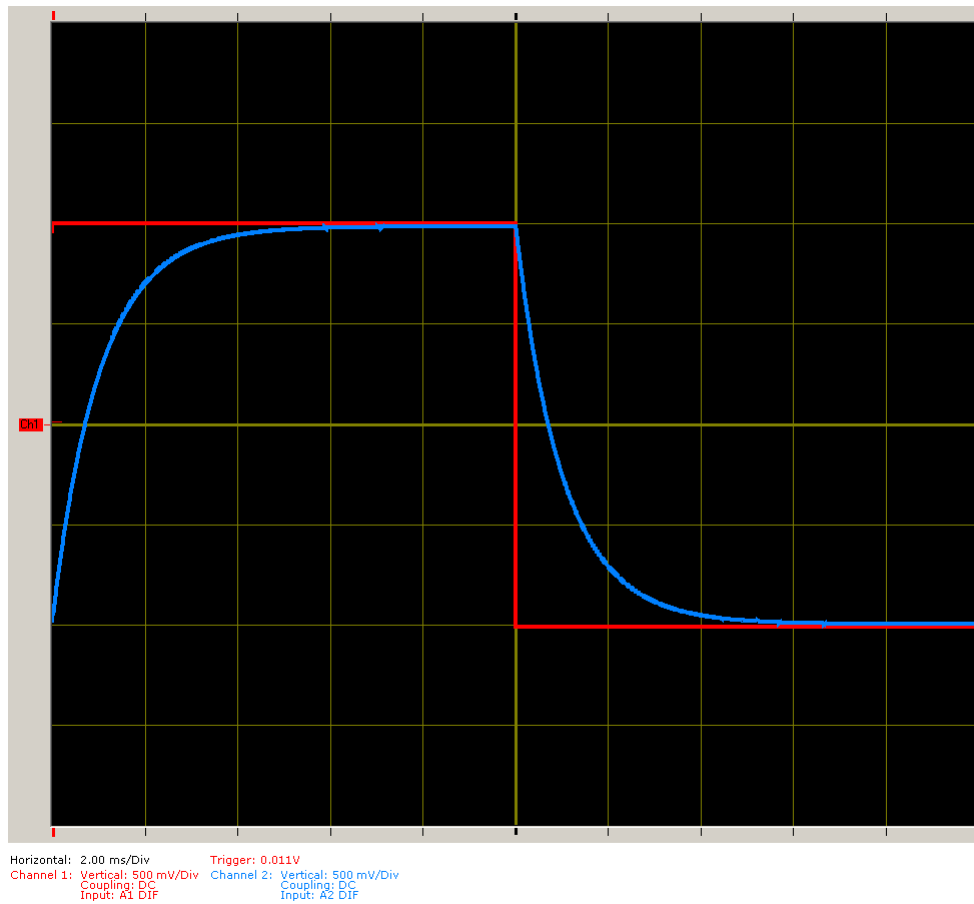

Figure 7. Open loop response of the plant. The output is measured across the load resistor connected to the isolating amplifier.

7) Connect all of the subsystems together, but do not connect the feedback loop. Your output should be very nearly the same as in Figure 7.

8) Remove the load resistor from the isolation amplifier, and connect the feedback loop. Measure the output of the system as the voltage across the capacitor. Do not change any of the variable resistances yet. You should get a response like that in Figure 8. Your output should be about half the amplitude of the open loop system (Figure

7) and should have a settling time about half as long (the time constant should be one half of its previous value.) Now we are ready to boogie.

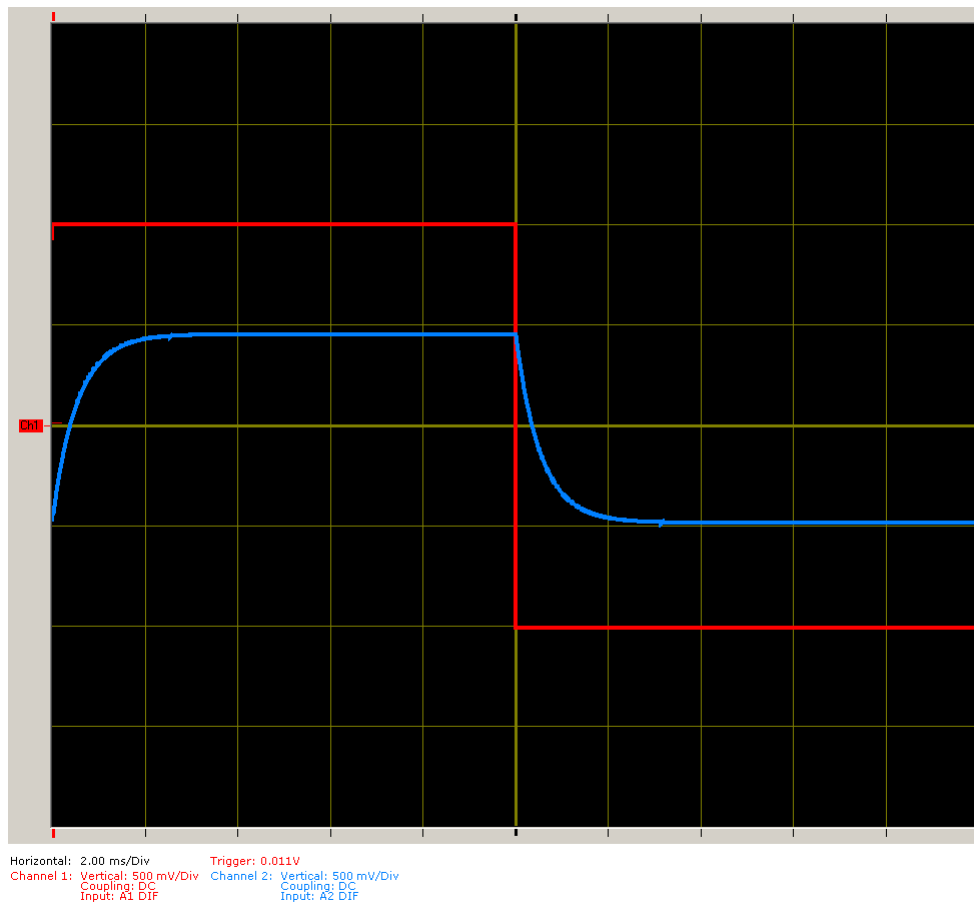

Figure 8. Closed loop response of the first order system with all gains approximately equal to one.

9) You are now going to have to iterate a bit. Slowly change the variable resistor on the controller to speed up the response of the system. Then change the resistor on the prefilter so the output is the same amplitude as the input. *You need to include two different screen captures in your memo, both showing the system is faster than the original and has the same output as the reference (input) signal.*

PART I I: Proportional Plus Integral Control for a First Order System

We will now change our proportional controller for a proportional plus integral controller. This requires only a slight modification to your circuit. Be sure you reconnect the system so the output goes through the isolation op-amp before being fed back. A proportional controller has the form

$$G_c(s) = k_p + k_i \frac{1}{s}$$

Both variable resistors in our controller directly affect the proportional gain (k_p), but only the second variable resistor affects the integral gain (k_i).

1) Modify the proportional controller circuit by adding a $1 \mu\text{f}$ capacitor and variable resistor, as shown in Figure 9.

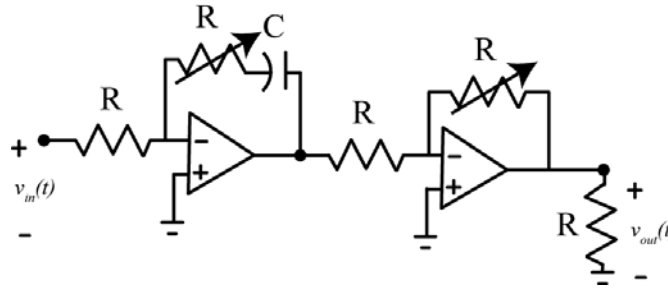

Figure 9. Proportional plus integral controller (with a load resistor attached)..

- 2) Set the variable resistors on the controller to someplace in the middle of their range, and adjust the prefilter gain so the steady state output matches the input.
- 3) Now go back and adjust the variable resistors on the controller. We can use these to change the gain of the proportional term and the gain of the integral term. You should note that as you change this resistor, the output still matches the input (as long as the system has time to reach steady state). This is the beauty of having an integral controller!
- 4) Adjust your controller so you get an output like that shown in figures 10 and 11 and *collect the two screen shots for your memo*. In particular, one screen shot (like Figure 10) should have a 100% overshoot and a settling time of approximately 10 msec, and the other screen shot (Figure 11) should have virtually no overshoot and a settling time of approximately 0.3 ms.

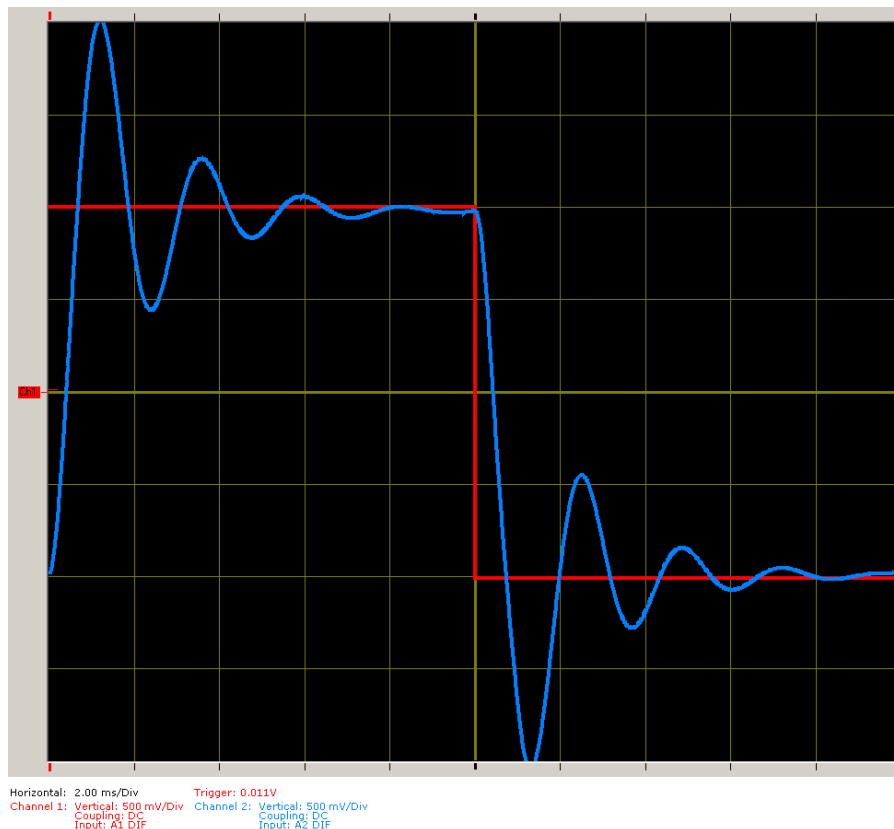

Figure 10. PI control of a first order system with 100% overshoot and a settling time of approximately 10 ms.

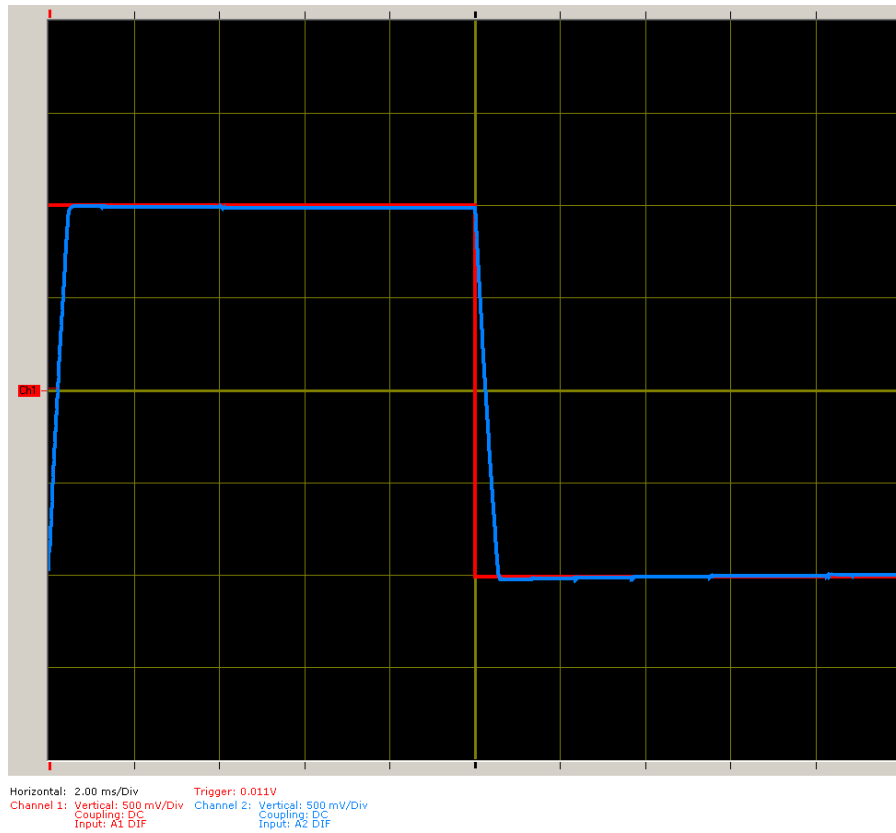

Figure 11. PI control of a first order system with 0% overshoot and a settling time of approximately 0.3 ms.

PART III: Proportional Plus Integral Control for a Second Order System

Now we are going to change the plant to a second order system and try to control it using the PI controller. This will not be as easy as the first order system, but it is typically more difficult to control a system as the system order increases.

- 1) Remove your old plant for the circuit board.
- 2) Modify your circuit so the plant and isolation amplifier is as shown in Figure 12. Again the resistor is 1 k Ω , but the capacitor is a 0.01 μ f capacitor, and the inductor is a 33 mH inductor (we've used the inductor and capacitor before in Lab 2).

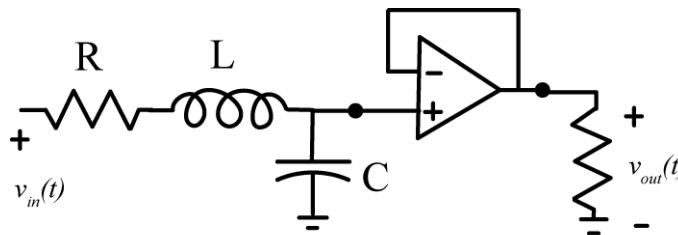

Figure 12. Our second order system

- 3) To make sure your plant (system) is correct, we will first test the plant, so you need to disconnect this system from the feedback system. Set the input to a 1 kHz square wave, and **Time/Div** to 100 μ s. The output is the voltage across the capacitor, and you should get a graph like that in Figure 13. Note that this system has a settling time of approximately 0.25 ms and about a 60 % overshoot. *Include a screen shot of this in your memo.*

4) Connect your system, or plant, to the feedback network and try to adjust the system so there is no overshoot and the settling time is less than approximately 0.8 ms, as shown in Figure 14. You may have to adjust the time scale and frequency of the signal generator to get a good picture. Be sure your system has reached steady state (it's flat on the top!) *Include a screen shot of this in your memo.* Note that in this case, we cannot speed up the response of the system if our goal is to reduce the overshoot.

You should remember that we are not changing our plants, or basic systems, but we are changing how they behave using feedback and an active controller to change the system characteristics.

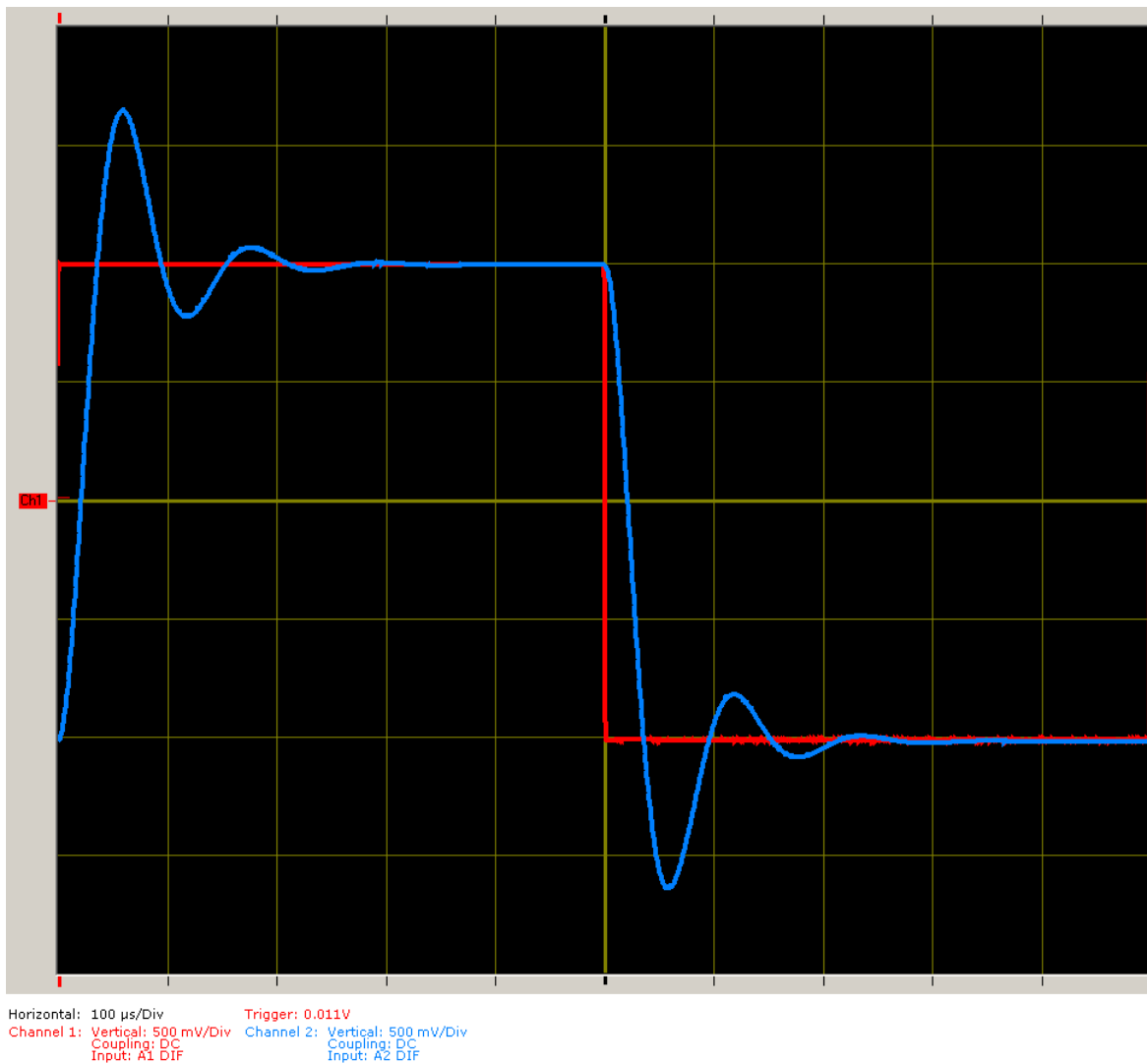
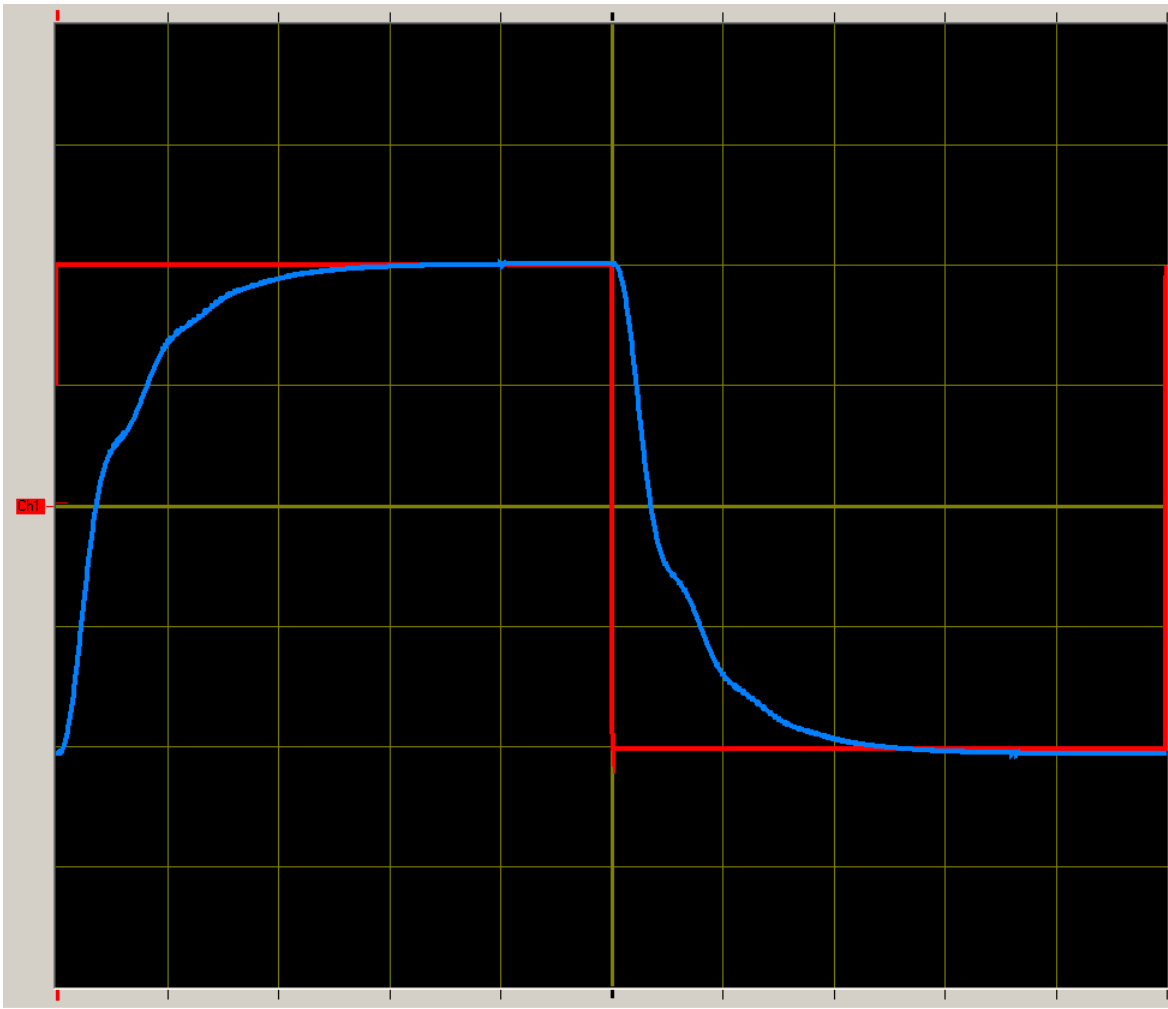

Figure 13. (Open loop) step response of our second order plant.



Horizontal: 200 μ s/Div Trigger: 0.011V
Channel 1: Vertical: 500 mV/Div Channel 2: Vertical: 500 mV/Div
 Coupling: DC Coupling: DC
 Input: A1 DIF Input: A2 DIF

Figure 14. Closed loop step response of our second order system with no overshoot.