

LAB #10: Analog Interfacing

You must checkoff this lab during your lab section of the week of April 16th. Lab writeup is due in class on April 24th. **NO LATE CHECKOFFS OR LAB REPORTS WILL BE ACCEPTED.**

1 Objectives

- Demonstrate a simple digital-to-analog converter.
- Gain experience with power transistors and op amps in reversed-input configuration.
- Understand a simple circuit that will use a high-impedance voltage output to control a 12V DC motor.
- Demonstrate analog control of a DC motor using the 6812 and an R-2R resistor ladder.
- Demonstrate that you can control (relatively) high voltage circuits without totally destroying sensitive digital circuits.
- Use the 6812 A/D converter system to capture arbitrary waveforms.

2 Reading

- Read Chapter 11 on analog interfacing.

3 Parts

- Resistors to build a 6-bit D/A converter using an R-2R ladder. Use R equal to 10K.
- To build your motor driver you will need the following:
 - 50K variable resistor (anything in 5K to 100K range should work)
 - 10K resistor (+/- 50%)
 - 741 op amp
 - TIP120 NPN transistor
 - 1N4004 diode
 - 47-200 uF capacitor
 - 12V DC servo motor (available for checkout in the lab).
- A 1K-10K resistor will be needed for the PAD0 analog input.

4 Background

In this lab, you will be building a 6-bit D/A converter using an R-2R ladder (see Figure 1), use it to control a 12V DC servo motor, and use the 6812 A/D converter system to check the value of your analog output signal. Your design will be controlled via commands over the serial port. Your interface should accept the following commands:

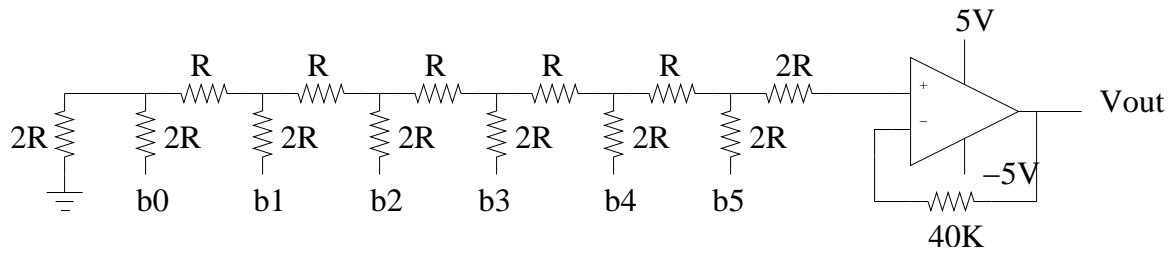

Figure 1: 6-bit D/A converter using an R-2R ladder.

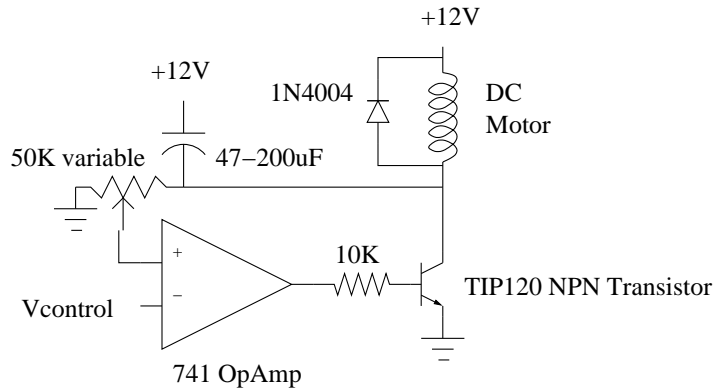

Figure 2: Motor driver circuit.

- a nn - set the output value connected to your D/A converter.
- t - create a triangle wave
- p hhhh - set the sample update period
- n hhhh - capture specified number of samples
- r - retrieve wave file; transmit ascii-hex over serial link

The “a nn” command will be used to set the 6-bit value (where “nn” is 0 to 63) that will be sent to your D/A. The “t” command simply starts from 0 and counts up to 63 outputting each value to the port connected to your D/A. You should wire the output of your D/A back through PAD0 to be sampled by the 6812 A/D converter. The “p hhhh” command sets how many cycles you want to wait between samples. The “n hhhh” command sets how many samples you want to take (each sample should be stored into RAM). Finally, the “r” command causes the program to perform the sampling, and when it is done to transmit the results back over the serial port. The last step is to construct the motor control circuit shown in Figure 2, and to control the motor speed using the “a nn” command.

CAUTION: Be very careful when building the motor driver circuit for this lab. The +/- 12V power supply for the op amp and DC motor can damage or destroy the integrated circuits in the digital portion of your circuit. If possible, use a separate half of the breadboard for the circuit above. Then only share the GND and D/A output lines between the two circuits. When connecting power to the 12V DC motor, be sure to use the power input connectors, not the tachometer output connectors. The power inputs are the pair nearest the shaft.

5 Prelab

1. Write code to parse the commands described above, set the port value connected to your D/A converter, and perform sampling of the analog signal using the 6812 A/D converter system.
2. Answer the following questions about the motor driver circuit before starting the lab.
 - (a) Assuming the TIP120's collector voltage is 0.7V when the transistor saturates, and assuming the coil resistance of the DC motor is 15 ohms, what is the maximum current draw (i.e., the stall current) of the motor?
 - (b) Assuming the DC current gain (h_{FE}) for the TIP120 is 1000, what is the base current that corresponds to this collector current?
 - (c) Assuming the maximum output of the op amp is 11.3V, and base voltage of the TIP120 is 0.7V, what is the largest value for the resistor connected to the transistor that will permit a base current up to the value computed in part b?
 - (d) Does the maximum motor current correspond to a Vcontrol value of 5V or 0V? Assume the motor is not loaded in either case.
 - (e) When the Vcontrol input is 0V, what value would you expect to see at the TIP120's collector? If the variable resistor is set to its midpoint, what value do you expect to see at the positive input to the op amp? What value would you expect at the op amp's output? Explain your reasoning.
 - (f) To completely turn off the motor, we would like to drive the op amp to its negative power rail when the Vcontrol input is 5V. What requirement does this place on the value of the op amp's positive input for a Vcontrol input of 5V? (You may simplify by assuming the the op amp has infinite open-loop gain.) If the TIP120's collector current is cutoff when the Vcontrol input is 5V, what is the collector voltage in this case? (You may assume negligible current through the variable resistor, for this question.) How does the variable resistor need to be set so that our requirement for the op amp's positive input is met? Express your answer as a percent, where 0% corresponds to a wiper position at the ground end of the resistor.

Each group can complete the prelab problems together. Group solutions to these problems are due at the beginning of the lab section during the week of April 16th.

6 Lab Tasks

1. Build a 6-bit D/A converter using an R-2R ladder. Use an output port to provide the digital signal to your D/A converter. Note: if you're feeling ambitious and would like to experiment with more resolution, feel free to implement a converter with 8 bits instead of 6.
2. Implement a serial port command "a nn" that will set the digital value of your D/A converter. Measure the voltages produced for at least 8 output values, including the minimum and maximum values.
3. Increase the voltage to your 6812 circuit by 5% (Keep it under 6 volts.) Take another measurement for the maximum output value of your D/A converter. Restore the 6812 circuit voltage to its original value.
4. Implement the "t" serial port command to create a repeating triangle wave by ramping up and down through all possible output values. Using HP Benchlink, capture a complete cycle of this waveform on the oscilloscope.
5. Check out a 12V DC motor and build the above motor driver circuit. Use +12V for the 741's VCC power supply, and -12V for the 741's VEE power supply. Do not connect this circuit to your 6812 circuit yet.

6. Adjust the variable resistor to the midway point. Verify that grounding the Vcontrol input results in maximum motor speed.
7. Now apply 5V at the Vcontrol signal. Put a scope on the collector of the TIP120. Adjust the variable resistor to control this collector voltage. Note how the voltage on the scope corresponds to the speed of the motor and to the variable resistor's wiper position. Experiment with the full range of the variable resistor.
8. Adjust the variable resistor to the point where the 5V control input is just high enough to drive the op amp all the way to its negative power rail. This will cut off current to the motor. Leave the variable resistor at this setting for the next step.
9. Power down the motor control circuit. Connect the ground of 6812 circuit to the ground of the motor driver circuit. Be careful not to connect any point in your 6812 circuit to +/- 12V. Connect the output of your 6-bit D/A converter to the negative input of the op amp. Make sure you don't confuse the -12V supply with GND.
10. Power up your 6812 circuit. Load and run your program, and set the output of the D/A to its maximum value (almost 5V). Verify the Vcontrol input is approximately 5V.
11. Power up the motor driver. The motor should be off. With the maximum D/A value for Vcontrol, again adjust the variable resistor so that this input is just high enough to drive the op amp to the negative power rail.
12. Using Hyperterminal, decrease the D/A output a step at a time and monitor the output of the op amp. You should be able to adjust the variable resistor so that the max value (\$3F) completely cuts off current to the motor, but smaller values (e.g., #3C and below) put the op amp into its linear range and allow current through the motor.
13. Experiment with different D/A values from the maximum value down to 0. Notice the point at which the motor starts to turn. By looking again at the op amp output, make a note of the D/A value at which the op amp saturates, allowing maximum current through the motor. Also note the value(s) of the op amp output when it's operating in its linear range (i.e., not driving to either power rail).
14. With the motor turning at some intermediate value, observe the op amp output on the scope. Remove the capacitor and see if the waveform changes. Make a capture of the scope screen with and without this capacitor.
15. Set up your 6812 circuit with an "A/D sampling in progress" LED.
16. Provide 5V to the 6812's VRH pin and 0V to the VRL pin.
17. Provide an under-voltage protection resistor (1K to 10K) at the PAD0 input.
18. Connect the output of your D/A converter to PAD0 through the resistor you added in the previous step.
19. Implement the "p hhhh" and "n hhhh" serial port commands to obtain the sample update period and number of samples from the user.
20. Implement the "r" command to obtain the number of requested samples from PAD0 at the desired updated period. The samples should be copied into RAM during sampling, and the LED connected to PA7 should be on during sampling. When sampling is complete, these sample values should be transmitted over the serial port.
21. Set your output to your D/A to some fixed value, and obtain a small number of samples to check that it works. Are the values constant? Next, set your output to your D/A to be a triangle wave and again obtain samples.

22. Connect PAD0 to a function generator to provide a 0-3V sine wave for high-impedance termination (this will look like 0-1.5V with 50-ohm termination) at the fixed resistor that is protecting PAD0. Caution: negative voltages can damage the A/D input. Be sure to connect a 1K-10K fixed resistor between the output of the function generator and the PAD0 input. Set up the frequency generator with a DC offset so that it produces non-negative voltages only.
23. Experiment with different frequencies of inputs, and different periods of sampling. Demonstrate what happens when the input frequency is close to the sample rate, when it is one half the sampling rate, when it is much faster, and when it is much slower. Provide graphs for each of these cases.

Hint: in Hyperterminal you can use the "Terminal->Capture Text..." menu command to capture the result of the 6812 r(etrieve) command. You should be able to plot this in Excel after converting from Hex using the hex2dec function. (You may need to use the Excel menu command "Tools->Add-Ins..." and select "Analysis ToolPak" before this function will work.) You should also be able to convert this data in Matlab using the hex2num function.

7 Writeup

Include the following items. In this lab, only one writeup per team is required.

1. Include a printout of your final programs and your HP Benchlink capture file.
2. Provide a graph of D/A output voltage versus digital value for the data you collected. Provide on the same graph the expected outputs for these digital values. Discuss/explain the discrepancies.
3. Include your graphs of the sampled waveforms. Provide, in each case, the input frequency and the sample rate (in Hz).
4. Describe any problems you encountered or unexpected observations you made.
5. Answer the following questions.
 - (a) How sensitive is your D/A converter to fluctuations in the 6812 circuit voltage? How might a commercial D/A converter deal with this problem?
 - (b) Assuming a 6-bit D/A converter and a voltage range of exactly 0 to 5 volts, what is the resolution of the output, in volts? (i.e., what voltage is associated with the least significant bit?)
 - (c) Is it conceivable that the function mapping input values to output voltages for this type of D/A converter not be strictly increasing? Explain.
 - (d) At what D/A digital values does the op amp completely cut off motor current? At what values does it drive the transistor into saturation?
 - (e) How much does the output of the op amp vary for different D/A values when it's operating in its linear range?
 - (f) What effect does removing the capacitor have? Suggest a reason why this is the case.
 - (g) When you held the voltage input constant, what was the range of A/D values recorded?
 - (h) For your capture of a sine wave with a frequency much slower than your sample rate, look at the differences between subsequent values. Estimate how much this data could be compressed by recording the differences rather than the absolute values.