

C & U

CREATIVE
& UNIQUE

MICROWAVE SERIES

EMI Test System MR2300

The first EMI total test system in the world
– Precompliance –

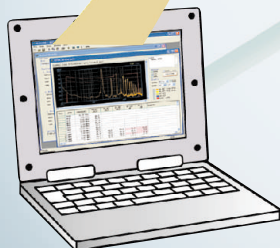
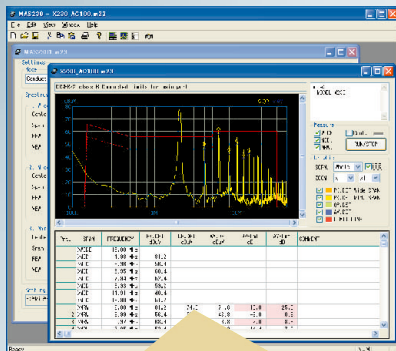

MICRONIX

About the EMI test

EMC test consists of EMS and EMI tests. As for the EMI test, it is evaluated whether the radiated emission or the conducted emission discharged from EUT (Equipment Under Test) exceeds the limit value set beforehand. This limit value is used to guarantee that the EUT operation doesn't give a remarkable disturbance to operation of other equipment and wireless communication.

On the other hand, EMS test evaluates whether EUT causes the malfunction by a peripheral electromagnetic radiation.

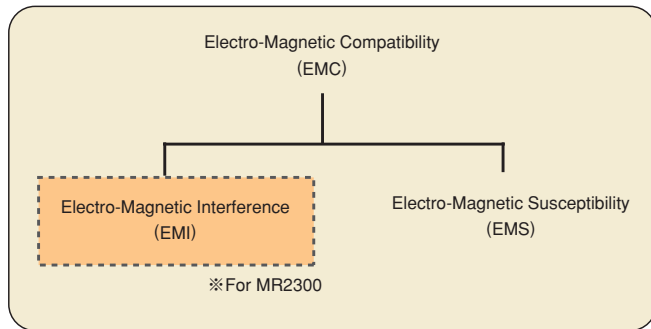

Generally or from our experience, it is said that the number or the solution time of the problems concerning EMI is 5 to 10 times larger than EMS. In short, passing EMI test means that 80 to 90 percents of EMC test are completed. Therefore, MR 2300 specializes in the EMI test.

What is MR2300 ?

Generally, much waiting time and cost are needed in a formal EMI test using the anechoic chamber. When it is repeated many times to solve the problem and to test formally, longer time and more cost are wasted. MR2300 focuses on being used to solve the problem in advance <<Precompliance>> and reducing the number of times of formal test to one or two times.

There was a partial EMI test system for precompliance since before. MR2300 is, however, the first total test system in the world, including even an anechoic box.

Under a recent air environment where the radio waves of TV and wireless communication equipment flit, the EMI test not using an anechoic box is impossible.

What can be done by MR2300 ?

◆ Two kinds of EMI tests can be carried out.

① Radiated emission test

This test can be performed in the frequency range 30MHz to 3GHz by using an anechoic box and a broadband antenna.

② Conducted emission test

This test can be performed in the frequency range 150kHz to 30MHz by using LISN (Line Impedance Stabilization Network).

◆ The source of noise can be found.

③ Magnetic field measurement of PCB in EUT

The source of the emission noise can be found by using a magnetic field probe CP-2S of option and measuring the magnetic field on the print circuit board.

The features of MR2300

MR2300 is an integration system that concentrates our spectrum analyzer technology, anechoic box technology and antenna technology.

1 The first EMI total test system in the world

As a complete and total test system including not only antenna, spectrum analyzer for EMI, LISN and PC software for EMI but also anechoic box, MR2300 is the first in the world. In addition, the magnetic field probe (option) is prepared as a problem solution tool. Any other additional equipment is not needed at all.

2 Compact and broadband antenna by our own development

The antenna, whose dimensions are as small as 578(W)×332(H)×500(D)mm (MAN101, excluding ground plate) and bandwidth is as broad as 30MHz to 3GHz, was developed by ourselves. The size of anechoic box also became small by miniaturizing the antenna.

3 Small and large anechoic boxes

MY5310 for small EUT and MY5410 for large EUT are prepared. MY5310 is equipped with a turntable of 220mm in diameter/ 10kg in load and MY5410 is equipped with a turntable of 756mm in diameter/ 100kg in load.

4 Calibration of the entire system

The calibration as the whole system like corrections of the antenna gain, attenuation of LISN and conversion into 3 meters in measurement distance is performed in MSA338E and PC software. The user only reads the measurement result on the PC screen as it is.

5 Conformity to regional and international standards

MR2300 is based on CISPR11(classA/B,group1), CISPR22(classA/B), EN55011(classA/B,group1), EN55022(classA/B), VCCI(classA/B) and FCC part15 subpartB(classA/B).

6 Low system price

The system price of MR2300 is much cheaper (i.e. one fifteenth to one thirtieth) than an existing system using anechoic chamber.

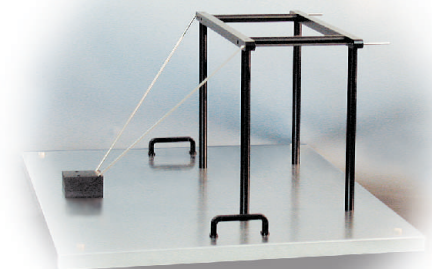

Broadband antenna

Explanation of whole system

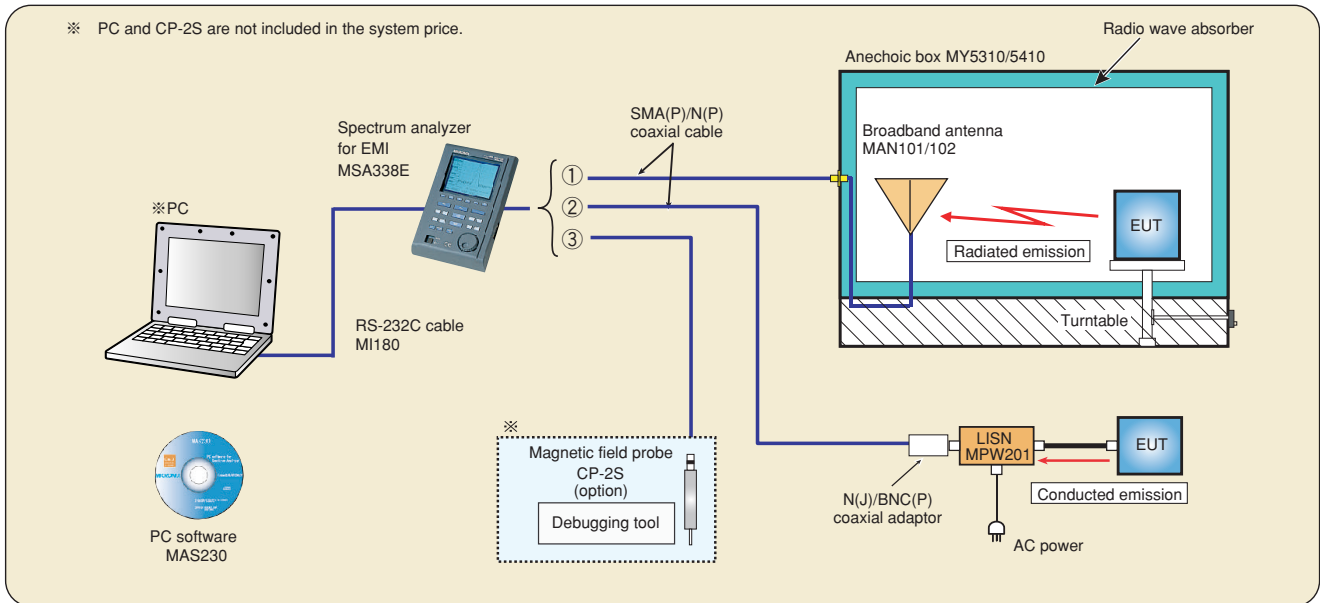

When ①, ② or ③ in the whole system chart shown above is connected to [RF INPUT] of Spectrum analyzer MSA338E for EMI, the radiated emission test, the conducted emission test or debugging to remove the source of disturbance noise respectively can be performed.

Connection of ① — Radiated emission test

By connecting anechoic box MY5310/5410 and MSA338E with an accessory SMA(P)/N(P) coaxial cable, the radiated emission test is done within 30MHz to 3GHz.

After receiving the disturbance noise that EUT (Equipment under test) radiates in the air with broadband antenna MAN101/102, it is input to MSA338E. The antenna gain of MAN101/102 is corrected and the electric field strength ($\text{dB } \mu\text{V/m}$) is calculated in MSA338E. The calculation result is displayed with the limit line by the EMI standard on the screen of a personal computer after forwarded there through the RS-232C communication and converted into 3 meters in measurement distance.

Connection of ② — Conducted emission test

By inserting an accessory N(J)/BNC(P) coaxial adaptor in the [RF OUT] terminal of LISN(MPW201) and then connecting to MSA338E with SMA(P)/N(P) coaxial cable, the conducted emission test is done within 150kHz to 30MHz.

The disturbance noise that EUT discharges into the power supply line is input to MSA338E through LISN. The attenuation of LISN is corrected and the noise is converted into the unit of $\text{dB } \mu\text{V}$ in MSA338E. The data is displayed with the limit line by the EMI standard on the screen of a personal computer after forwarded there through the RS-232C communication.

Connection of ③ — Search of the source of disturbance noise

The magnetic field distribution on a print circuit board can be precisely measured by using magnetic field probe CP-2S of option. As a result, it is very convenient as a debugging tool because the source of disturbance noise that exceeds the limit line can be easily found out.

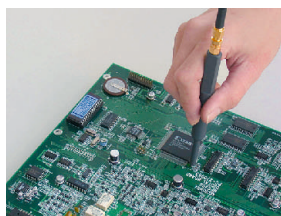

<About magnetic field probe CP-2S>

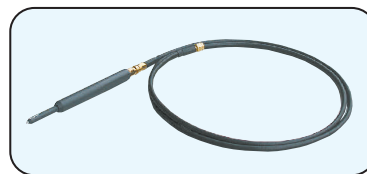

As the magnetic field detection portion of CP-2S is of a shielded loop structure that adopts glass ceramic multi-layer board technology of excellent high frequency characteristics, it is possible to measure at high reproducibility by detecting magnetic field components only. The measuring frequency range is as broad as 10MHz to 3GHz, and the measured value is calibrated in MSA338E.

Items	Specifications
Frequency range	10MHz to 3GHz
Space resolution	approx. 0.25mm (depending on objects)
Dimensions	outside: $12 \phi \times 135\text{mm}$ probe tip: $2\text{mm(W)} \times 1\text{mm(T)}$
Connector	SMA(P)

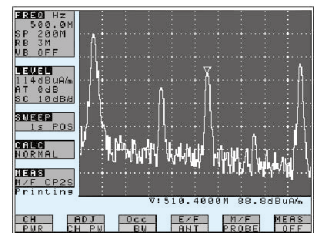

Moreover, CP-2S is not affected by adjacent patterns because of high space resolution.

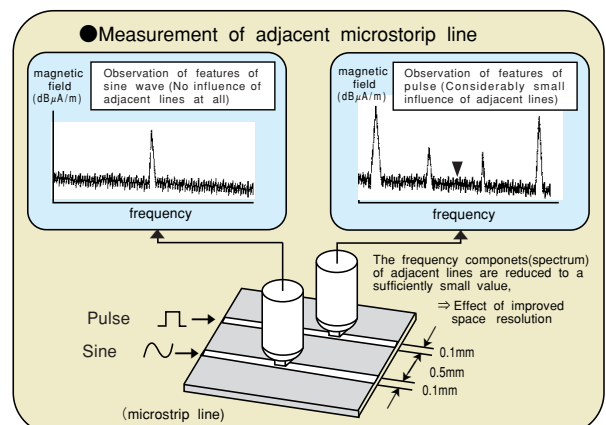

※ When observing the spectrum on PC screen, PC software MAS300 (option) is necessary separately.

Anechoic box & Broadband antenna

Anechoic box MY5310



The limit value of the radiated emission in CISPR22/classB is as slight as 37 dB μ V/m in the frequency range 230 to 1000 MHz. Under the air environment where the radio waves of cellular phone, TV and radio flit, the disturbance noise radiated from EUT is buried in these signals and cannot be measured. Therefore, the measurement in an anechoic box is required. MY5310 has the turntable of 220mm in diameter and 10kg in load. This is for such a comparatively small EUT (Equipment under test) as not sticking out from the turntable. The turntable can be turned with the rotary knob installed outside. Moreover, the rotation angle can be accurately set by watching the rotation indicator. MY5310 is equipped with MAN101 as a broadband antenna. The measured values on the screen of a computer can be directly read because MSA338E and PC software correct the frequency characteristics of antenna gain and the distance between the antenna and EUT. Additionally, a power supply outlet, D-sub connector and N type coaxial connector installed for EUT save the trouble of wiring.

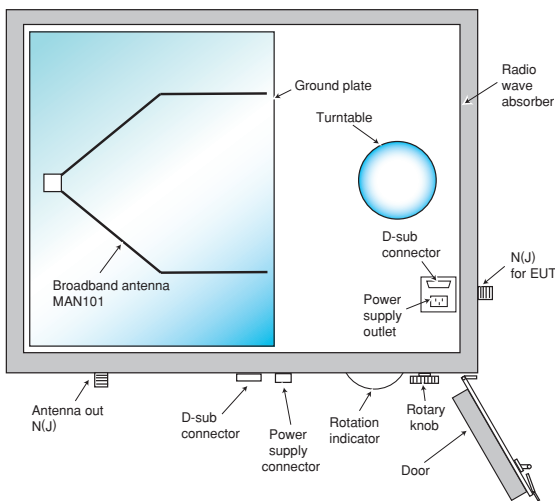

The ferrite tile used as radio wave absorber has the absorption characteristics shown in the right figure. The unnecessary reflection and resonance in the anechoic box are suppressed as much as possible because of the absorption efficiency of 20 dB or more in the frequency range 80MHz to 2GHz.

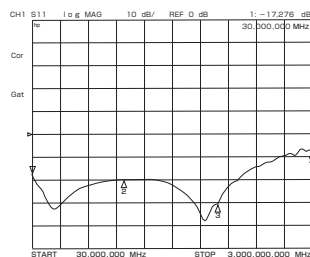

Anechoic box MY5410



MY5410 is an anechoic box for a large EUT and with the turntable of 756mm in diameter and 100kg in load. As for the broadband antenna, MAN102 is installed. Moreover, the antenna can be moved up and down in maximum 90cm width each 10cm by hand with the antenna trestle installed. The radio wave absorber is the same one as MY5310.

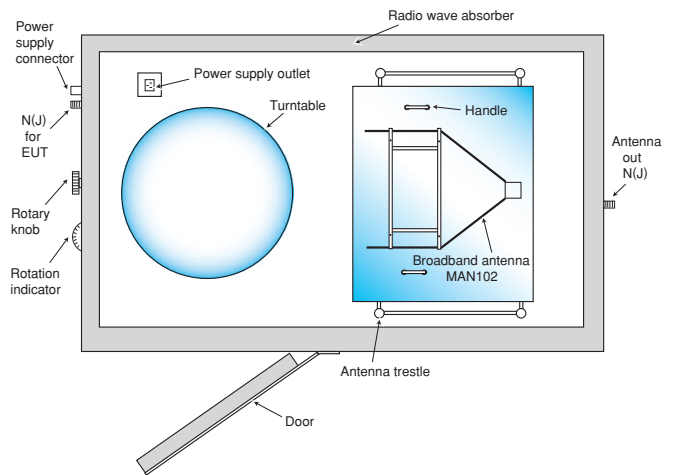

Broadband antenna MAN101/102

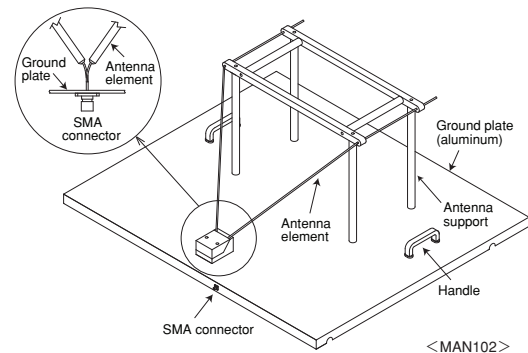

The existing antenna in the frequency range 30MHz to 3GHz is not able to be installed in the anechoic box because of the extremely large size such as 1.7m in length and width. A transformational Y character monopole antenna (the original name by us) with the frequency bandwidth 30MHz to 3GHz was developed by ourselves and greatly miniaturized.

The EMI test became possible even in a comparatively small anechoic box by that success. The structure of MAN101 and MAN102 is almost same but MAN102 is a little larger in length of antenna element and size of ground plate. The directivity of a monopole antenna is the same as that of a dipole antenna, which is symmetric with respect to the ground plate, in the upper area of the ground plate from the principle of the mirror image. Furthermore, when thinking about the distance of the antenna and EUT, the receiving reference point of the antenna is the position of the signal pin of SMA connector where two antenna elements intersect.

Line impedance stabilization network (LISN) MPW201



When the conducted emission discharged through the power supply line is measured, the measured value is influenced from the impedance of the power source. The noise level is measured low if the impedance is low, and it is measured high if oppositely high. With this, there are neither universality nor reliability in the measured value. Then, to measure the disturbance noise with stability and reproducibility, the impedance of the power source should be made constant. The impedance of the power source observed from EUT side is made constant by inserting the line impedance stabilization network in the power supply line. However, the impedance of power supply line has the frequency characteristics but the impedance curve is provided by CISPR.

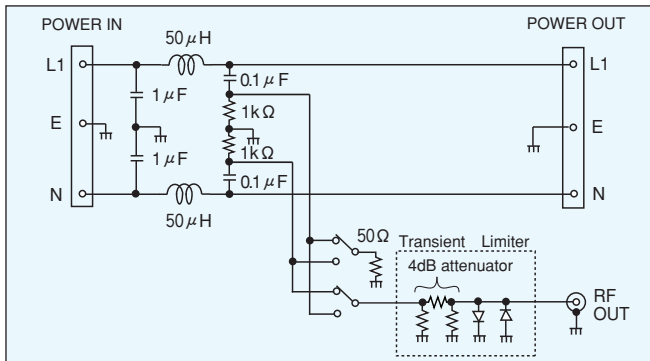

LISN equivalent circuit

The circuit of MPW201 adopts <50Ω/50 μH and V type> based on CISPR 16-1. The frequency range is from 150kHz to 30MHz, and the conditions of power supply are single phase, maximum voltage 250VAC, rated current 10A and 50/60Hz.

As shown in the equivalent circuit, the disturbance noise discharged from EUT is led to a transient limiter with 50Ω input through a high pass filter of cutoff frequency 33kHz composed of a capacitor (0.1 μF) and resistors (50Ω//1kΩ), and then input to Spectrum analyzer MSA338E. The disturbance noise can be measured at both terminals of L1 and N, but a high voltage transient pulse may be generated when switching the measurement line. To protect the spectrum analyzer from this pulse, a transient limiter composed of 4dB attenuator and diodes is built in. The gain correction of 4dB attenuator is automatically done in MSA338E.

Spectrum analyzer for EMI MSA338E



Measurement mode and Preset

It is possible to select from three measurement modes shown below. The troublesome setting for EMI test is unnecessary because the parameters corresponding to the measurement mode are automatically preset.

Measurement mode	Function key	Preset
Normal measurement	NORM (F1)	Preset initial parameters of normal mode
Conducted emission measurement	EMI-C (F2)	Preset initial parameters of conducted emission mode
Radiated emission measurement	EMI-R (F3)	Preset initial parameters of radiated emission mode

Detection mode

MSA338E has the three detection modes of PK(peak), QP(quasi-peak) and AV(average). The expression of $PK \geq QP \geq AV$ is approved in the detection level as shown in the figure below. Additionally, $PK=QP=AV$ is right in case of a narrowband signal like the CW wave.

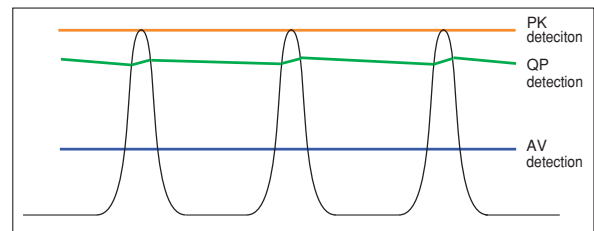

The PK detection is achieved by setting the measurement mode to normal measurement, the detection mode to PosPeak and the calculation function to MaxHold. By the way, a signal of time width 200ns or more can be detected by PosPeak detector because the sampling speed of A/D converter is 5MS/s. The fast sweep time can be used when observing the disturbance noise in the PK detection mode because its time constant is much smaller than QP or AV. Therefore, it is convenient to use the PK detection when narrowing the disturbance noise spectrums out of specification to small number. The QP detection is usually used in both of the radiated and conducted emissions measurements, and the AV detection is usually used in the conducted emission measurement. The measurement time can be shortened by using them in the final measurement to the spectrums narrowed by the PK detection.

Resolution bandwidth(RBW)

CISPR provides that the radiated and conducted emissions should be measured with RBW filters of 9kHz and 120kHz respectively. The bandwidth is a value at 6dB down. MSA338E also has five RBW filters besides these two filters, whose bandwidths at 3dB are 3kHz, 30kHz, 300kHz, 1MHz and 3MHz.

Horizontal axis data of 1000 points

Although the spectrum is displayed by 250 points on the horizontal axis of the screen of MSA338E, it is fetched by 1000 points per sweep in the instrument. All of these 1000 points are transferred to a personal computer (the maximum transfer rate is 38,400bps) and displayed on the PC screen after processed by PC software MAS230. The image, therefore, becomes clearer.

PC software MAS230

As MR2300 can be easily used even if inexperienced in the operation of a spectrum analyzer and EMI test, the parameters of spectrum analyzer and typical EMI standards are preset. Furthermore, to simplify the procedures from searching out the spectrums out of specification until measuring with QP or AV detection, the automatic measurement mode is prepared. By the way, the measurement value of the radiated emission is converted into 3 meters in measurement distance.

Setting of measurement parameter

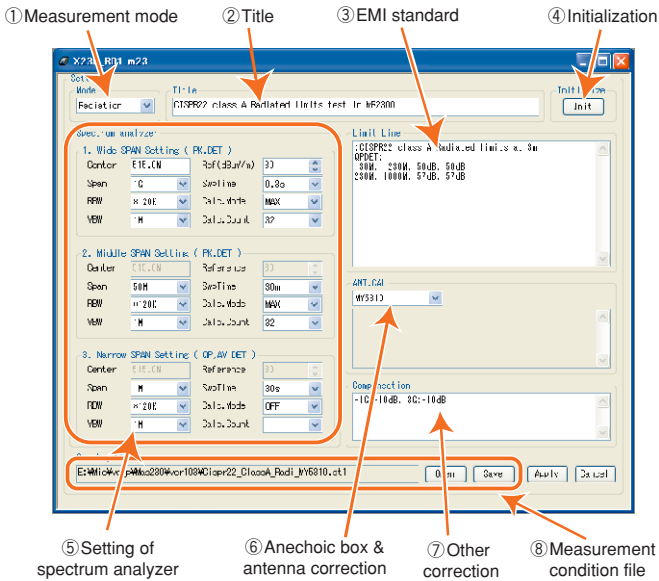

① Selection of measurement mode

The radiated or conducted emission measurement is selected.

② Entry of title

The title of the test is entered. The content is arbitrary because this is a comment sentence.

③ Setting of EMI standard value

As the main standards are stored in the file explained in item ⑧, the necessary standard is selected and set from among them after opening it. The standard value not supported or the original value of user is input with the format like the example shown below.

```
;CISPR22 class B Conducted limits for main port
QPDET:
0.15M, 0.50M, 66dB, 56dB, log
0.50M, 5M, 56dB, 56dB
5M, 30M, 60dB, 60dB
AVDET:
0.15M, 0.50M, 56dB, 46dB, log
0.50M, 5M, 46dB
5M, 30M, 50dB
```

④ Setting of initialization

The various setting values in the current measurement mode are set to the initial values. They mean the setting parameters of the spectrum analyzer, the setting values of EMI standard, the correction coefficient of the anechoic box & antenna (or LISN) and other correction coefficient.

⑤ Setting of Spectrum analyzer

The frequency span is divided into three bands of Wide, Middle and Narrow for the automatic measurement or for shortening the measurement time. The center frequency and the sweep time are set in each span. However, as all of the setting parameters are stored in the file, it is possible to set them easily by opening it.

⑥ Setting of correction coefficient of anechoic box & antenna

The corrections of the distance between EUT and antenna in the anechoic box and the frequency characteristics of antenna are performed. Two kinds of correction values are automatically set by designating an anechoic box because the anechoic box and the antenna are a couple, for instance MAN101 is always installed in MY5310. However, the attenuation of LISN is corrected in the conducted emission measurement. These correction values are usually set by opening the file but the original correction values by user can be also input.

⑦ Setting of other correction coefficient

When the frequency characteristics of a coaxial cable and other should be corrected, this setting is useful. MR2300 has no correction data in this item.

⑧ Measurement condition file

The table below shows the files for CISPR22 as an example. All the standards supported (refer to "Standards supported" in Specifications described in the final page) are made to the files.

CISPR 22classA/powerline conducted emission	: Cispr22_ClassA_Cond_MainPort. st1
CISPR 22classB/powerline conducted emission	: Cispr22_ClassB_Cond_MainPort. st1
CISPR 22classA/radiated emission	: Cispr22_ClassA_Radi_MY5310. st1
CISPR 22classB/radiated emission	: Cispr22_ClassB_Radi_MY5310. st1

Automatic measurement

If measured in the wide span with the QP or AV detection all at once, the measurement time becomes very long because the time constant of these detections is very large. Therefore, the measurement is first performed in the wide span with the PK detection, in which the measurement time is short, from the expression of $PK \geq QP \geq AV$, and then only spectrums out of specification are measured with the PK detection as well in the middle span. In addition, only spectrums out of specification even in this middle span are measured with the QP or AV detection in the narrow span. Even if the detection mode is QP or AV, the measurement time is only 30 seconds in the radiated emission measurement or only 10 seconds in the conducted emission measurement because the frequency span is narrow.

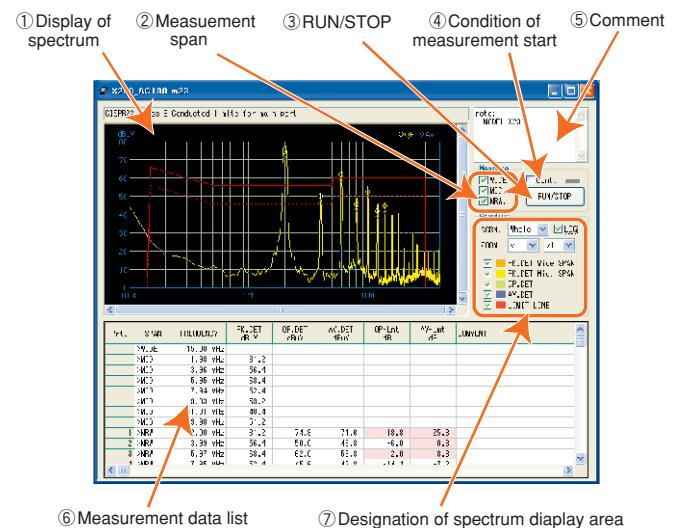

① Display of spectrum

The measured spectrum of the disturbance noise and the limit line of the EMI standard are displayed. The solid line shows a limit line of the QP detection and the broken line shows a limit line of the AV detection. Besides, the level measured in the QP or AV detection is displayed on the spectrum with ○ or ◇ mark respectively.

② Selection of measurement span

When all of wide span (WIDE), middle span (MID) and narrow span (NRW) are selected, all the procedures until measuring spectrums out of specification with the QP or AV detection are automatically carried out.

The measurement in each span can be independently performed, but only spectrums out of specification in the wide span or the middle span are measured by the middle span or the narrow span respectively.

③ RUN/STOP

The measurement starts or stops.

④ Condition of measurement start

If it is off, the measurement starts newly after deleting the measured data. If it is on, the unmeasured spectrum is measured by continuing the last measurement.

⑤ Comment

The comment sentence is entered.

⑥ Measurement data list

[SPAN] shows in which span the measurement is done and ">" is marked after finishing the measurement. [PK.DET], [QP.DET] or [AV.DET] displays the measured value by PK, QP or AV detection respectively. In the wide span and the middle span, only the measured value by the PK detection is displayed. [QP-Lmt] or [AV-Lmt] means the value in which the limit value is subtracted from the measured value by QP or AV detection respectively. Furthermore, when [SPAN] is selected and [DEL] key is pushed, that line and the related data are deleted.

⑦ Designation of spectrum display area

- SCRN : When "Whole" is selected, the whole of spectrum display area is displayed, and when "Part" is selected, the area of selection cell shown by ▽ marker is displayed.
- LOG : The frequency axis is displayed in logarithm.
- ZOOM : The display magnification is changed.
- Display/non-display: On/off of each display item is selected.

< About minimum detection level >

In the measurement with the wide span or the middle span, the measurement finishes at this point when there is no noise exceeding the limit line. Therefore, there is no data by the QP or AV detection because the measurement is not continued. Then, the spectrum larger than 5dB low from the limit line is considered as a noise out of specification if -5dB is set in the wide span as shown by the example of picture.

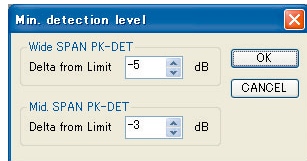

Manual measurement

The manual measurement is very convenient for debugging EUT and removing the disturbance noise. It is possible to measure by freely setting the center frequency, the frequency span and so on.

- ① Setting of Spectrum analyzer ② RUN/HOLD

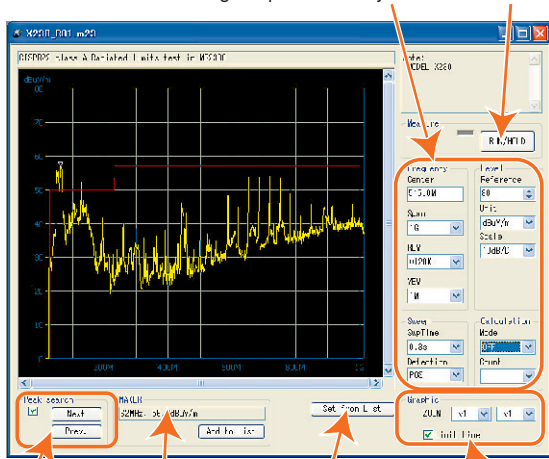

- ③ Peak search ④ Marker data ⑤ Setting of parameters ⑥ Designation of spectrum display area

① Setting of Spectrum analyzer

MSA338E is set. It is recommended to set to PosPeak detection and MaxHold (off) when debugging, and QP/AV detection and MaxHold (on) when confirming finally.

② RUN/HOLD

Capturing the signal is restarted or stopped.

③ Peak search

The peak level of spectrum is searched and the marker moves to that point. The next smaller level is searched by Next. Prev is opposite against it.

④ Marker data

The data in the marker point is displayed. The marker moves with the peak search or the mouse.

⑤ Setting of parameters

When [Set from List] is clicked by a mouse after designating a line of the measurement data list on the automatic measurement screen, the measurement condition of this line is set as parameters of the manual measurement.

⑥ Designation of spectrum display area

On/off of the display magnification and the limit line is set.

<Reference> Standards of the world

① CISPR (Comite International Special des Perturbations Radioelectriques)

Basic standards	
CISPR16-1	Specification for radio disturbance and immunity measuring apparatus and methods Part1: Radio disturbance and immunity measuring apparatus
Product standards	
CISPR11	Limits and methods of measurement of radio disturbance characteristics of industrial, scientific and medical (ISM) radio frequency equipment
CISPR12	Limits and methods of measurement of radio disturbance characteristics of vehicles, motor boats and spark-ignited engine driven devices
CISPR13	Limits and methods of measurement of radio disturbance characteristics of sound and television broadcast receivers and associated equipment
CISPR14-1	Limits and methods of measurement of radio disturbance characteristics of electrical motor-operated and thermal appliances for household and similar purposes, electric tools and similar electric apparatus
CISPR14-2	Requirements for household appliances, tools and similar apparatus. Part2: Immunity
CISPR15	Limits and methods of measurement of radio disturbance characteristics of electrical lighting and similar equipment
CISPR20	Limits and methods of measurement of immunity characteristics of sound and television broadcast receivers and associated equipment
CISPR22	Limits and methods of measurement of radio disturbance characteristics of ITE
CISPR24	Limits and methods of measurement of the immunity characteristics of ITE
CISPR25	Limits and methods of measurement of radio disturbance characteristics for the protection of receivers used on board vehicles

② CENELEC (European Committee for Electrotechnical Standardization)

CENELEC and CISPR are almost same. The corresponding table of two standards is shown right.

CENELEC	CISPR
EN55011	CISPR 11
EN55012	CISPR 12
EN55013	CISPR 13
EN55014	CISPR 14
EN55015	CISPR 15
EN55020	CISPR20
EN55022	CISPR22

③ FCC (Federal Communications Commission / USA)

Standards	Contents
Part15	Regulations relating to unnecessary emission of various radiofrequency equipments including broadcast receiver and computer
Part18	Regulations relating to industrial, scientific and medical equipments

④ VCCI (Voluntary Control Council for Interference by Information Technology Equipment / Japan)

CISPR16-1 and CISPR22 are quoted.

Specifications

System specifications

Measurement mode	Radiated and conducted emissions measurements ※The magnetic field strength measurement with Magnetic field probe CP-2S is performed in Magnetic field strength measurement mode in Measuring functions of MSA338E.
Frequency range	30MHz to 3GHz @Radiated emission measurement 150kHz to 30MHz @Conducted emission measurement
Standards supported	CISPR11(classA/B.group1), CISPR22(classA/B), EN55011(classA/B.group1), EN55022(classA/B), VCCI(classA/B), FCC part15 subpartB(classA/B)

Anechoic box (MY5310/5410)

Items	MY5310	MY5410
Outside dimensions	1340(W)×1210(H)×1030(D)mm (excluding casters and projections)	2310(W)×1840(H)×1390(D)mm (excluding casters and projections)
Inside dimensions	1230(W)×920(H)×920(D)mm	2140(W)×1450(H)×1220(D)mm
Door opening dimensions	410(W)×710(H)mm	890(W)×1490(H)mm
Weight	approx.460kg	approx.1000kg
Turntable dimension	220mm φ	756mm φ
Turntable load	10kg	100kg
Radio wave absorber	Ferrite tile structured double	Ferrite tile structured double
Connector	Coaxial	N(J)@antenna out N(J)@for EUT
	D-sub	25 pins
Power supply for EUT	AC250Vmax, three-pin plug	AC250Vmax, three-pin plug
Shielding efficiency	more than 65dB	more than 50dB
Absorption efficiency	more than 20dB @0.1 to 2GHz	more than 20dB @0.1 to 2GHz

Broadband antenna (MAN101/102)

Frequency range	30MHz to 3GHz
Polarization	Linear
Impedance	50Ω (nominal)
Antenna type	Transformational Y character monopole antenna (original name by us)

Dimensions

	MAN101	MAN102
Element	578(W)×332(H)×500(D)mm	628(W)×332(H)×500(D)mm
Ground plate	700(W)×900(D)mm	800(W)×950(D)mm

Weight	approx.5.3kg (including ground plate) @MAN101 approx.6.0kg (including ground plate) @MAN102
--------	--

LISN(MPW201)

Frequency range	150kHz to 30MHz
Circuit type	50Ω/50μH and V type based CISPR16-1
Impedance accuracy	within ±20%
Number of phase	Single
Max. power supply voltage	250VAC
Rated current	10A
Power supply frequency	50/60Hz
RF connector	BNC female
Transient limiter	Built-in
Operating temperature	0 to 40°C (Guaranteed at 23±10°C)
Dimensions	250(W)×133(H)×230(D)mm
Weight	approx.2.8kg

Spectrum analyzer for EMI (MSA338E)

Detection	Peak, Quasi-peak and Average detections												
Time constant of QP	<table border="1"> <thead> <tr> <th>Time constant \ RBW</th> <th>9kHz</th> <th>120kHz</th> </tr> </thead> <tbody> <tr> <td>Charge</td> <td>1ms</td> <td>1ms</td> </tr> <tr> <td>Discharge</td> <td>160ms</td> <td>550ms</td> </tr> <tr> <td>Mechanical</td> <td>160ms</td> <td>100ms</td> </tr> </tbody> </table>	Time constant \ RBW	9kHz	120kHz	Charge	1ms	1ms	Discharge	160ms	550ms	Mechanical	160ms	100ms
Time constant \ RBW	9kHz	120kHz											
Charge	1ms	1ms											
Discharge	160ms	550ms											
Mechanical	160ms	100ms											
Resolution bandwidth	3kHz, 9kHz(6dB), 30kHz, 120kHz(6dB), 300kHz, 1MHz and 3MHz ※RBWs excluding 9kHz and 120kHz are defined at 3dB down.												
Other specifications	Same as MSA338												

PC software (MAS230)

Recommended PC	CPU clock : more than 1GHz Memory : more than 128MB HD remainder capacity : more than 500MB Communication port : RS-232C
OS	Windows2000, XP(excluding 64bits version)

Others

Operating temperature	0 to 40°C (Guaranteed at 23±10°C)
Operating humidity	less than 40°C/80%RH (Guaranteed at less than 33°C/70%RH)
Storage temperature	-20 to 60°C, less than 60°C/70%RH
Standard accessories	<ul style="list-style-type: none"> SMA(P)/N(P) 1.5m coaxial cable(1pc.) N(J)/BNC(P) coaxial adaptor(1pc.) RS-232C cable MI180(1pc.) Power cable for MY5310/5410(1pc.) Power cable for MPW201(1pc.) MSA338E accessories(1set) Operating manual(1pc.)
Options	<ul style="list-style-type: none"> Magnetic field probe CP-2S PC software for MSA338E MAS300

MICRONIX Corporation reserves the right to make changes in design, specifications and other information without prior notice.

MICRONIX

MICRONIX CORPORATION

2987-2, KOBIKI-CHO, HACHIOJI-SHI, TOKYO 193-0934 JAPAN

TEL. +81-426-37-3667 FAX. +81-426-37-0227

URL: <http://www.micronix-jp.com>

AGENCY